

TRIAO

CONTROLS

A Division of A-T Controls, Inc.

***Pneumatic Rotary Actuators
and Accessories***



TRIAO

RACK & PINION FEATURES

TRIAQ

TRIAQ pneumatic actuators are designed and manufactured to provide the highest cycle-life on the market. We can accessorize them to accomplish virtually any control requirement. They are available with various mounting dimension configurations and span eleven models for appropriate torque compatibility. Our extensive inventory and engineering capabilities allow us to respond to your needs with flexibility. We pride ourselves on exceeding customer expectations. Contact us for application assistance.

- ▶ Double acting and spring return
- ▶ Dual travel stops
- ▶ Torques to 36,000 in.lbs.
- ▶ DA and SR common end caps
- ▶ ISO 5211 mounting dimensions
- ▶ Wide base for direct mount to many butterfly valves
- ▶ Substantial pinion bearings mean high cycle life
- ▶ Corrosion resistant hard anodized finish
- ▶ Each unit serialized and bar coded
- ▶ Namur accessory mounting configuration
- ▶ Custom accessory mounting

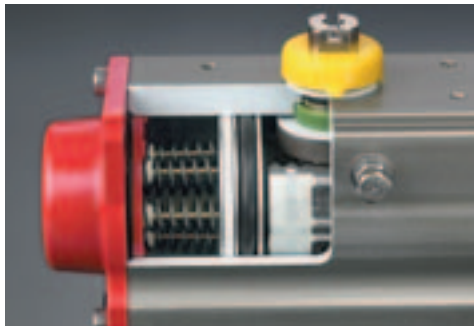

See accessory page for details

GENERAL TECHNICAL DATA

TRIA

- Standard working temperature -20°F to 175°F
- Low temperature and high temperature option
- Maximum working pressure 150 psig
- Operating media - clean, dry air, non-corrosive gas or light hydraulic oil

- Air supply 40 psi - 150 psi
- Rotation 100°
- Dual travel stops standard
- Mounting dimensions
 - Accessories to Namur - VDI/VDE
 - Valve mounting to ISO 5211 (TR20 - 2R1750)
 - Custom configurations available in quantity
- Permanently lubricated units

Operation

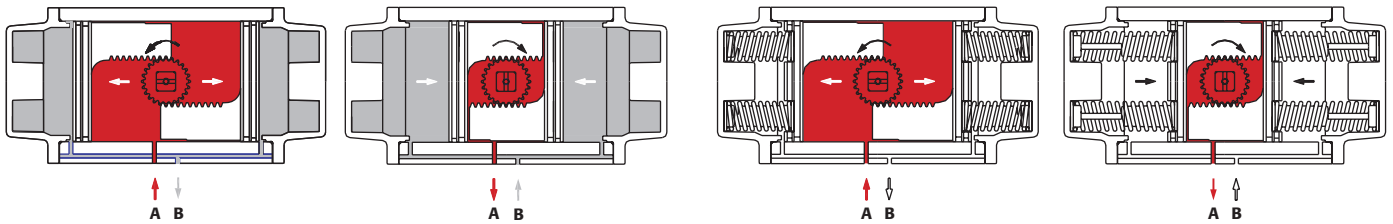

Double Acting Operation

CCW

Air is supplied to Port A forcing the pistons away from each other (toward ends), rotating drive pinion counterclockwise and exhausting air out of Port B.

CW

Air is supplied to Port B forcing the pistons toward each other (toward center), rotating drive pinion clockwise and exhausting air out of Port A.

Spring Return Operation

CCW

Air is supplied to Port A forcing the pistons away from each other (toward ends), rotating drive pinion counterclockwise, compressing springs and exhausting air out of Port B.

FAIL CW

Air failure (loss of pressure) allows compressed springs to force pistons toward each other (toward center), rotating drive pinion clockwise and exhausting air out of Port A.

*(Unit is capable of failure in counterclockwise direction by reversing pistons inside of housing.)

Torque Curves

TR10-2R1750 Rack & Pinion Design

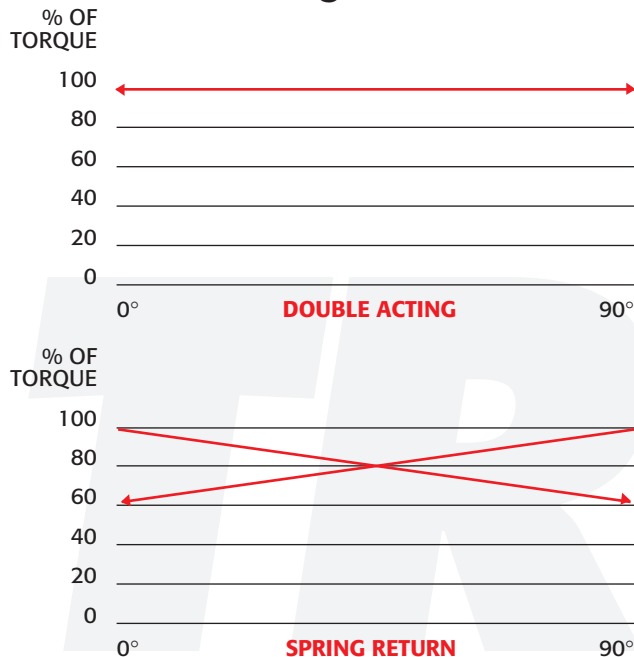

2R2500-2R3500 Scotch Yoke Design

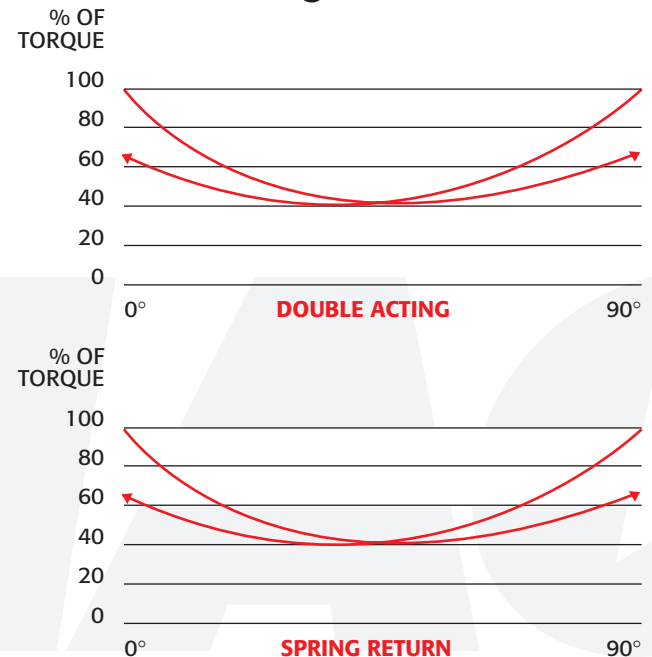

TORQUE OUTPUT & OPERATION INFORMATION



SPRING RETURN TORQUE (in. lbs.)

MODEL	SPRINGS/ SIDE (5 STD.)	SPRING TORQUE		AIR SUPPLY							
		40 psi	60 psi	80 psi	100 psi	END	BREAK	END	BREAK	END	BREAK
TR20SR	2	19	31	36	48	77	89	94	115	139	160
	3	29	49	20	40	60	80	94	115	139	160
	4	39	67			42	70	78	106	113	145
	5	49	84			25	60	61	96	105	135
	6	59	101					43	85	88	121
2R40SR	2	33	59	63	89	125	151	159	196		
	3	49	87	27	54	98	135	159	196		
	4	65	114			70	119	131	180	194	243
	5	82	142			43	103	103	164	165	226
	6	98	170					75	147	137	209
2R80SR	2	86	160	185	259	358	432	447	564		
	3	128	245	101	218	273	390	447	564	536	696
	4	170	330			188	348	362	522	455	651
	5	215	410			109	304	282	477	455	651
	6	260	490					202	432	375	605
2R130SR	2	120	226	233	339	473	579	586	744		
	3	185	343	117	275	356	514	586	744		
	4	250	460			239	449	469	679	720	930
	5	315	573			127	385	357	614	607	864
	6	380	685					244	549	494	799
2R200SR	2	168	310	339	481	669	811	849	1057		
	3	252	460	190	398	519	727	849	1057		
	4	336	610			369	643	699	973	1030	1304
	5	420	760			220	560	549	889	879	1219
	6	504	910					399	805	729	1135
2R300SR	2	350	644	745	1039	1445	1739	1827	2264		
	3	525	962	428	865	1127	1564	1827	2264		
	4	700	1280			809	1389	1509	2089	2200	2780
	5	880	1605			485	1210	1184	1909	1874	2599
	6	1060	1930					859	1729	1549	2419
2R500SR	2	530	920	1109	1499	2129	2519	2679	3264		
	3	795	1380	650	1235	1669	2254	2679	3264		
	4	1060	1840			1209	1989	2219	2999	3231	4010
	5	1325	2300			750	1725	1759	2734	2769	3744
	6	1590	2760					1299	2469	2309	3479
2R850SR	2	740	1230	1499	1989	2929	3419	3644	4379		
	3	1100	1835	1095	1830	2324	3059	3644	4379		
	4	1460	2440			1719	2699	3039	4019	4320	4300
	5	1815	3050			1110	2345	2429	3664	3709	4944
	6	2170	3660					1819	3309	3099	4589
2R1200SR	2	1050	1820	2029	2799	4189	4959	5169	6324		
	3	1575	2730	1120	2275	3279	4434	5169	6324		
	4	2100	3640			2369	3909	4259	5799	6140	7680
	5	2625	4550			1460	3385	3349	5274	5169	7094
	6	3150	5460					2439	4749	4259	6569
2R1750SR	2	1390	2430	3049	4089	6124	7164	7664	9224		
	3	2085	3645	1835	3395	4909	6469	7664	9224		
	4	2780	4860			3694	5774	6449	8529	9100	11,180
	5	3475	6075			2480	5080	5234	7834	7884	10,484
	6	4170	7290					4019	7139	6669	9789

TORQUE OUTPUT & OPERATION INFORMATION



TR10DA - 2R1750DA DOUBLE ACTING TORQUE (In-Lbs)

MODEL	AIR SUPPLY (psi)				
	40	60	80	100	120
TR10DA	30	45	60	75	90
TR20DA	79	118	158	197	237
2R40DA	164	245	327	409	491
2R80DA	352	528	703	879	1055
2R130DA	527	791	1054	1318	1581
2R200DA	716	1,073	1,431	1789	2147
2R300DA	1,217	1,825	2,434	3042	3651
2R500DA	1,749	2,624	3,498	4373	5247
2R850DA	3282	4923	6565	8206	9847
2R1200DA	4510	6765	9020	11275	13530
2R1750DA	5729	8586	11448	14311	17173

NOTE:
Torque shown are for 2R Series (ISO), 2CI Series (Centerline Direct Mount, and 2K Series (Keystone Direct Mount)

Torques are actual. Please be sure to include appropriate safety factors for all service condition variables when sizing.

3-way (master slave) assemblies should use a 35% safety factor. Call factory for assistance.

Spring Return (In-Lbs) Spring Clockwise Direction

2R2500SR

	Air Break	Run	Air End	Spring Break	Run	Spring End
60 psi	9,854	4,000	5,612	6,000	2,500	3,480
80 psi	12,258	4,750	6,403	9,080	3,950	5,520

2R3500SR

	Air Break	Run	Air End	Spring Break	Run	Spring End
60 psi	19,700	8,000	11,200	12,000	5,000	6,900
80 psi	24,500	9,500	12,800	18,100	7,900	11,000

Double Acting Torque (In-Lbs)

2R2500DA

	0 deg	Min	90 deg
60 psi	13,334	6,667	11,610
80 psi	17,778	8,890	15,483
100 psi	22,223	11,110	19,350

2R3500DA

	0 deg	Min	90 deg
60 psi	26,650	13,330	23,200
80 psi	35,550	17,750	30,960
100 psi	44,440	22,200	38,700

NOTE:
2R2500 and 2R3500 are scotch yoke design.

Consult factory for 2R2500DAR and 2R3500DAR (reverse acting) torque chart

Spring Return (In-Lbs) Spring Counter Clockwise Direction

2R2500SR

	Air Break	Run	Air End	Spring Break	Run	Spring End
60 psi	7,522	4,160	6,000	6,240	2,330	2,760
80 psi	9,500	5,110	6,432	7,800	3,600	4,200

2R3500SR

	Air Break	Run	Air End	Spring Break	Run	Spring End
60 psi	15,000	8,200	12,000	12,400	4,600	5,410
80 psi	19,000	10,200	12,800	15,600	7,200	8,400

DIMENSIONS TR20-2R1750

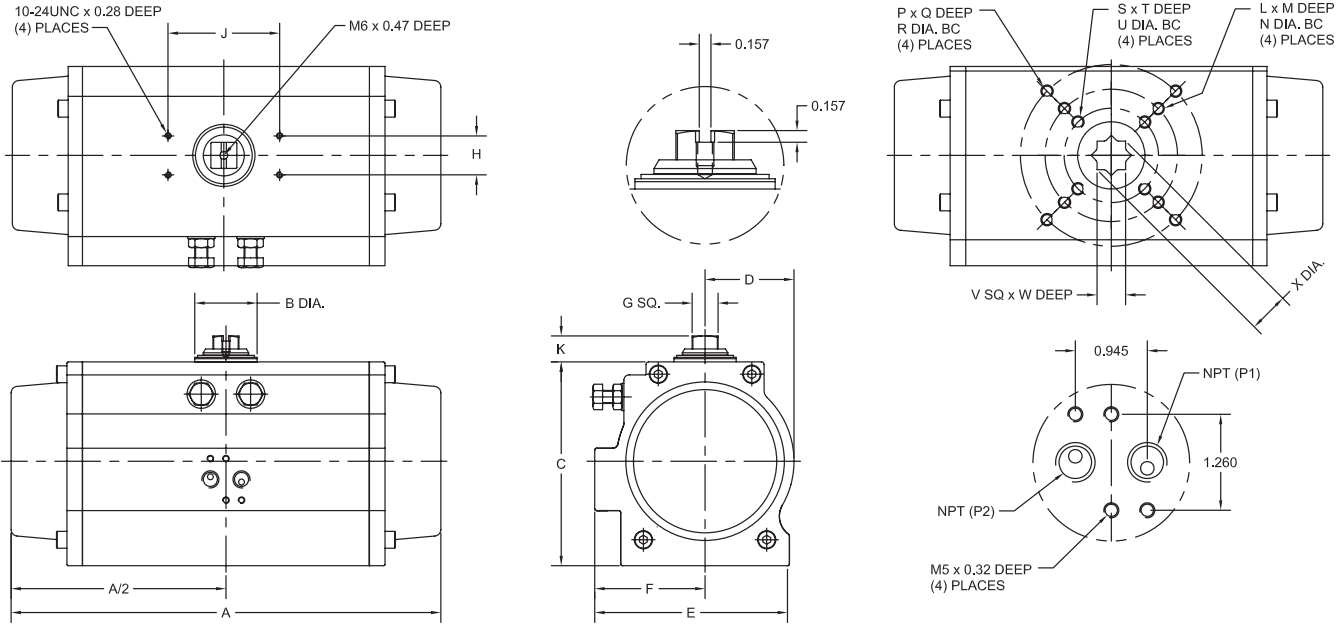

Model	TR10	TR20	2R40	2R80	2R130	2R200	2R300	2R500	2R850	2R1200	2R1750
A	4.57	5.98 / 7.60	7.95	9.29	10.87	11.46	13.90	15.16	20.95	22.68	24.37
B Dia.	0.79	1.22	1.22	1.22	1.42	1.61	1.89	2.09	2.40	2.68	2.91
C	1.91	2.76	3.43	4.49	4.88	5.28	6.18	6.93	8.31	9.17	10.12
D	0.83	1.10	1.42	1.69	2.11	2.30	2.70	2.99	3.74	4.13	4.57
E	1.93	2.58	3.29	4.41	4.69	5.06	5.91	6.50	6.89	7.60	8.31
F	1.10	1.40	1.79	2.48	2.72	2.89	3.35	3.70	3.90	4.29	4.72
NPT	1/8"	1/8"	1/8"	1/4"	1/4"	1/4"	1/4"	1/4"	1/4"	1/4"	1/4"
Accessory Mounting Dimensions											
G Sq.	0.354	0.630	0.630	0.630	0.630	0.630	0.787	0.787	0.787	1.260	1.260
H	0.984	1.181	1.181	1.181	1.181	1.181	1.181	1.181	1.181	1.181	1.181
J	1.969	3.150	3.150	3.150	3.150	3.150	3.150	5.118	5.118	5.118	5.118
K	0.787	0.787	0.787	0.787	0.787	0.787	0.787	1.181	1.181	1.181	1.181
Valve Mounting Dimensions											
ISO	F03	F04	F05/F07	F05/F07/F10	F07/F10	F07/F10	F07/F10/F12	F10/F12	F10/F12	F14	F14
U Dia.	1.417	1.654	1.969	1.969	N/A	N/A	2.756	N/A	N/A	N/A	N/A
N Dia.	N/A	N/A	2.756	2.756	2.756	2.756	4.016	4.016	4.016	N/A	N/A
R Dia.	N/A	N/A	N/A	4.016	4.016	4.016	4.921	4.921	4.921	5.512	5.512
S	10-24	1/4"-20	1/4"-20	1/4"-20	N/A	N/A	5/16"-18	N/A	N/A	N/A	N/A
L	N/A	N/A	5/16"-18	5/16"-18	5/16"-18	5/16"-18	3/8"-16	3/8"-16	3/8"-16	N/A	N/A
P	N/A	N/A	N/A	3/8"-16	3/8"-16	3/8"-16	1/2"-13	1/2"-13	1/2"-13	5/8"-11	5/8"-11
T	0.24	0.31	0.39	0.39	N/A	N/A	0.47	N/A	N/A	N/A	N/A
M	N/A	N/A	0.47	0.47	0.47	0.47	0.63	0.63	0.63	N/A	N/A
Q	N/A	N/A	N/A	0.63	0.63	0.63	0.79	0.79	0.79	0.87	0.87
V sq.	0.354	0.433	0.551	0.748	0.748	0.748	0.866	1.063	1.063	1.417	1.417
W	0.39	0.63	0.67	0.71	0.71	0.71	1.02	1.18	1.18	1.58	1.58
X	0.58	0.58	0.75	1.02	1.02	1.02	1.19	1.47	1.47	1.97	1.97
Weight (Lbs.)											
DA	2.2	2.9	4.5	9	12	14.5	23	32	59	78	100
SR	N/A	3.5	6	11	14	17	26	38	68	91	117
Volume (Cubic Inches per 90 Deg's)											
CW	3	8	16.5	34	52	67	116	183	334	505	703
CCW	3	6	14	23	36	49	100	137	259	357	439
Cycle Times (Seconds per 90 Deg's)											
DA	0.3	0.5	0.6	1	1.2	1.5	2	2.5	3	4	5
SR	n/a	0.5	0.6	1	1.2	1.5	2	2.5	3	4	5

TR10 & TR20 have travel stops located in the End Caps for travel adjustment in one direction.
2R40 & 2R80 have travel stops on the opposite side as shown.

Direct Acting:

Pressure at port P1 will result in a clockwise rotation
Pressure at port P2 will result in a counter clockwise rotation

Reverse Acting:

Pressure at port P1 will result in a counter clockwise rotation
Pressure at port P2 will result in a clockwise rotation

DIMENSIONS 2R2500 – 2R3500

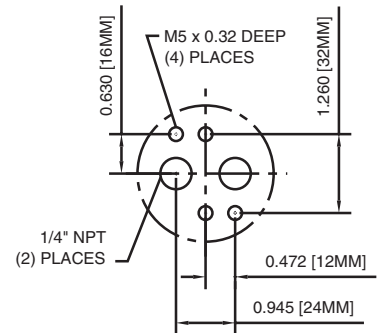
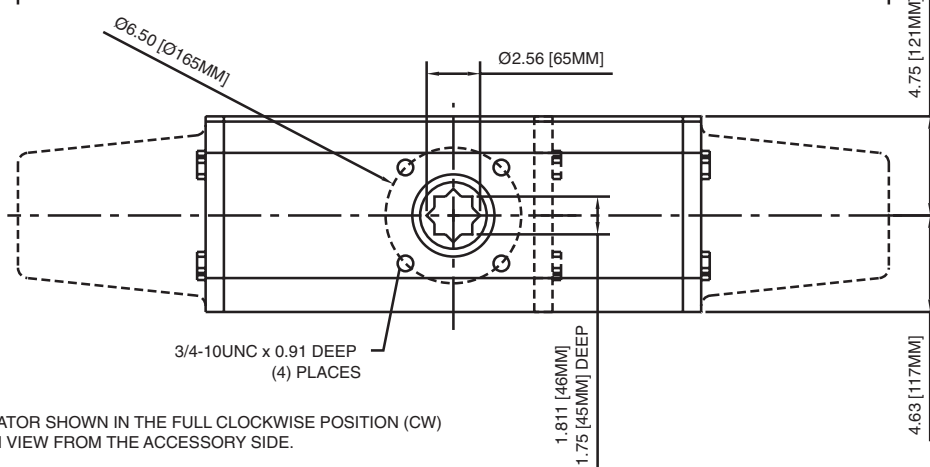
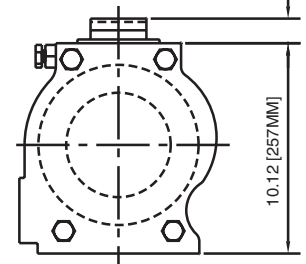
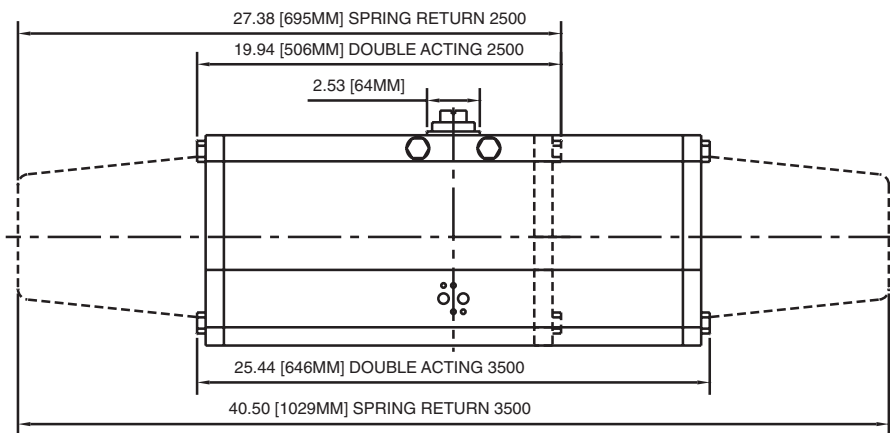
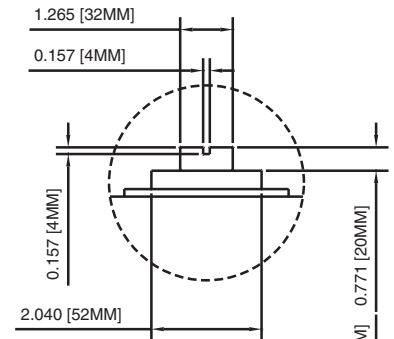
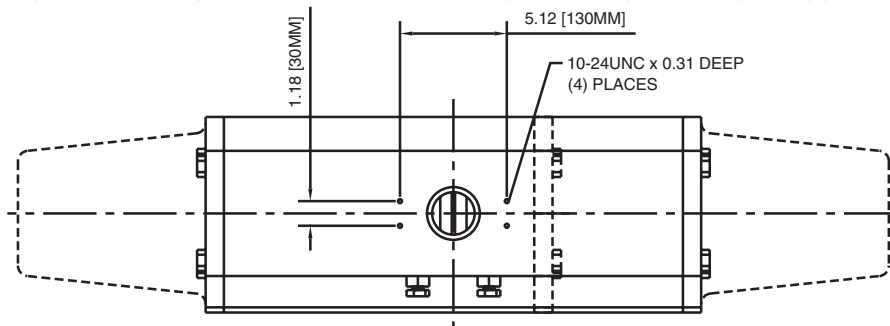

NAMUR MOUNTING

ACTUATOR SHOWN IN THE FULL CLOCKWISE POSITION (CW) WHEN VIEW FROM THE ACCESSORY SIDE.

WEIGHT (POUNDS)		VOLUME (CU. IN. PER 90 DEG)		CYCLE TIMES (SEC. PER 90 DEG)	
-----------------	--	-----------------------------	--	-------------------------------	--

MODEL	DA	SR	CW	CCW	CW	CCW
2R2500	98	137	525	310	5	5
2R3500	125	195	650	585	9	9

$$\text{Air Consumption (scf per 90 Deg)} = \frac{\text{Volume}}{1,728} \times \frac{\text{Supply Pressure} + 14.7}{14.7}$$

NOTES: Accessory mounting holes are not intended for Manual Gear Overrides or Stop Blocks. Cycle times are under no load conditions. Air line size, air capacity, and valve torque characteristics affect these cycle times. Faster or slower cycle times can be accomplished using special control components.

DIRECT MOUNT FOR BUTTERFLY VALVES



- ▶ Available for many of the most popular resilient seated butterfly valves
- ▶ Call for details and availability
- ▶ Usually requires no additional hardware
- ▶ Lower profile packages
- ▶ Wide base accommodates pattern without transition plate

TRIAC actuators feature a wide base to enable direct mounting to many butterfly valves without transition plates. Contact factory for compatibility with your particular butterfly.

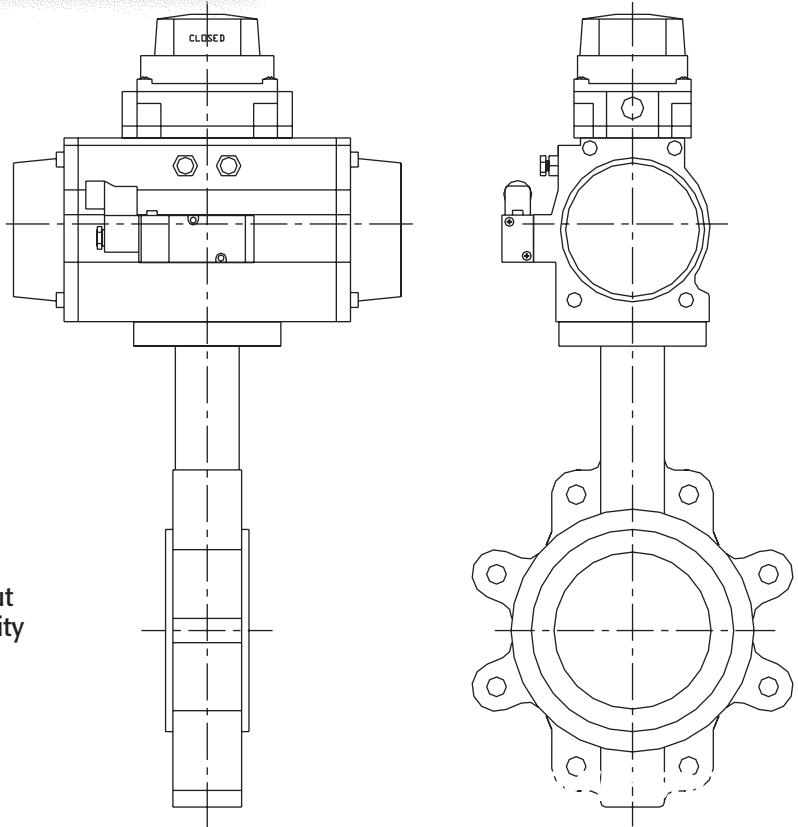

Dimensions – 2K Series

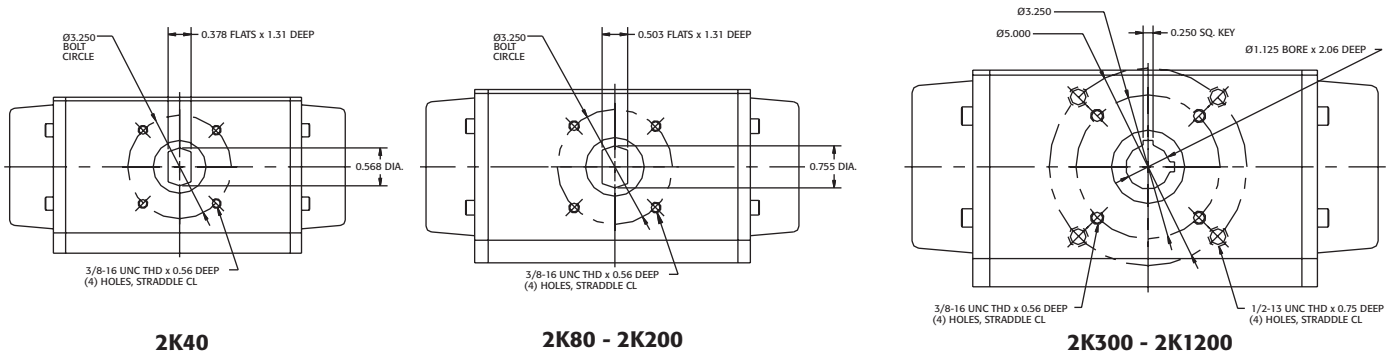

Note: 2K850 and 2K1200 have only 5" bolt circle

Adapter Dimensions for 2K Series

Refer to valve dimensions for actual sizing

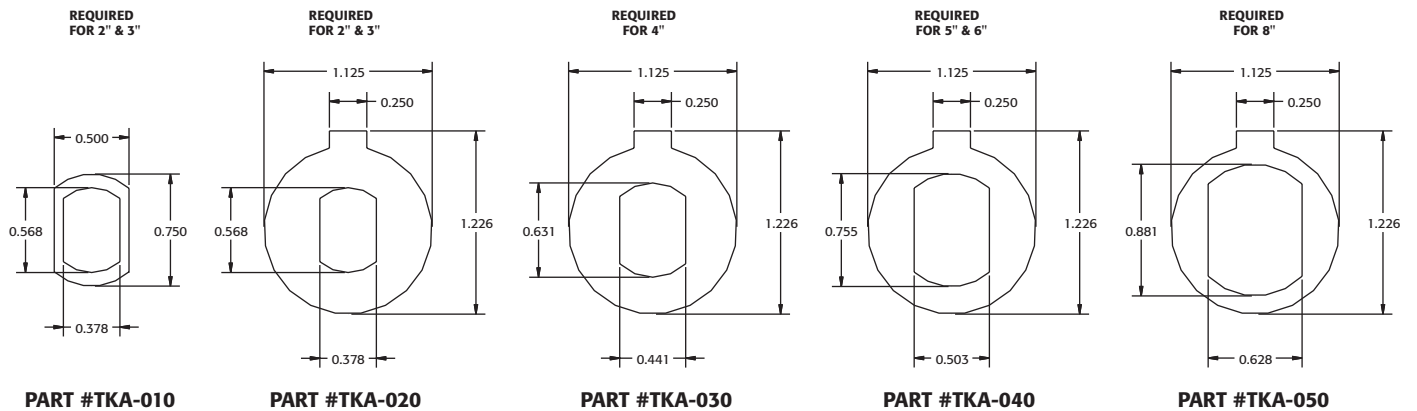

Other inserts are available on request.

DIRECT MOUNT ACTUATORS FOR CENTERLINE BUTTERFLY VALVES

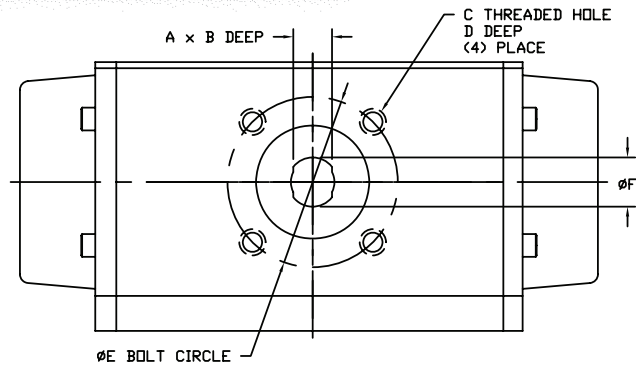

MODEL	A	B	C	D	E	F
2CI40**/2-3	0.394	1.31	5/16-18	0.47	2.756	0.50
2CI80**/2-3	0.394	1.31	5/16-18	0.47	2.756	0.50
2CI80**/4	0.472	1.31	5/16-18	0.47	2.756	0.63
2CI80**/5-6	0.551	1.31	5/16-18	0.47	2.756	0.75
2CI130**/2-3	0.394	1.31	5/16-18	0.47	2.756	0.50
2CI130**/4	0.472	1.31	5/16-18	0.47	2.756	0.63
2CI130**/5-6	0.551	1.31	5/16-18	0.47	2.756	0.75
2CI200**/4	0.472	1.31	5/16-18	0.47	2.756	0.63
2CI200**/5-6	0.551	1.31	5/16-18	0.47	2.756	0.75
2CI300**/5-6	0.551	1.31	5/16-18	0.47	2.756	0.75
2CI300**/8	0.669	1.81	3/8-16	0.63	4.016	0.88
2CI300**/10	0.866	1.81	3/8-16	0.63	4.016	1.13
2CI500**/8	0.669	1.81	3/8-16	0.63	4.016	0.88
2CI500**/10	0.866	1.81	3/8-16	0.63	4.016	1.13
2CI500**/12-14	0.945	1.81	3/8-16	0.63	4.016	1.25
2CI850**/10	0.866	1.81	3/8-16	0.63	4.016	1.13
2CI850**/12-14	0.945	1.81	3/8-16	0.63	4.016	1.25
2CI1200**/10	0.866	1.81	3/8-16	0.63	4.016	1.13
2CI1200**/12-14	0.945	1.81	3/8-16	0.63	4.016	1.25

Inserts for use with 2R Series Actuators

As shown on page 6

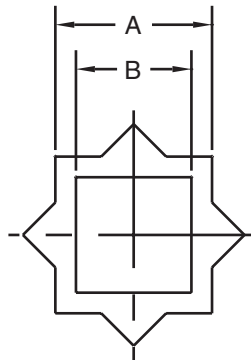

STAR INSERTS	A	B
ATD11T09	0.433	0.354
ATD14T09	0.551	0.354
ATD14T11	0.551	0.433
ATD19T09	0.748	0.354
ATD19T11	0.748	0.433
ATD19T14	0.748	0.551
ATD19T17	0.748	0.669
ATD27T17	1.063	0.669
ATD27T19	1.063	0.748
ATD27T22	1.063	0.866

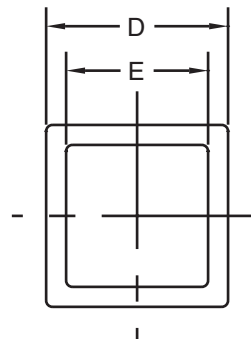

SQUARE INSERT	D	E
ATE14T09	0.551	0.354
ATE14T11	0.551	0.433
ATE17T14	0.669	0.551
ATE22T14	0.866	0.551
ATE22T17	0.866	0.669
ATE22T19	0.866	0.748
ATE26T17	1.023	0.669
ATE35T22	1.378	0.866
ATE36T27	1.417	1.063

ACCESSORIES

Solenoid Valves

- ▶ Direct mount TVC series
- ▶ Nipple mount available
- ▶ Weatherproof/explosion proof construction
- ▶ Intrinsically safe coil available
- ▶ Various voltages - AC or DC
- ▶ Quick exhaust modification
- ▶ 2 or 3 position control
- ▶ Exhaust speed controls



TVCS-X411-4N
Direct Mount Solenoids
All Accessory Options Available

APL & EX Series Limit Switches

- ▶ Aluminum housing
- ▶ Weatherproof/explosion proof construction
- ▶ Dome indicator
- ▶ Easy-Set cams
- ▶ Captive bolts
- ▶ many switch options
- ▶ AS-I systems
- ▶ Can be mounted on manual valves



APL-310

Stainless Steel Pneumatic Actuators



See stainless steel actuator brochure for details and information.

Positioners



PPR and EPR Series

Declutchable Gear Overrides



DGO Series

Other Accessories and Controls



- ▶ Lock-up valves
- ▶ Filter regulators
- ▶ Special tubing/fittings
- ▶ Lockout/tagout hardware
- ▶ Flow controls
- ▶ Speed controls
- ▶ Custom assemblies
- ▶ Dribble control
- ▶ Specials
- ▶ Complete mounting and assembly service

Sample Specification

Actuator shall be TRIAC TR/2R series rack and pinion design. Body to be hard anodized, extruded aluminum for corrosion protection and shall have a base wide enough for stable mounting to valve mounting pads. Internals to feature dual aluminum piston racks and a one-piece electroless nickel plated blow-out proof pinion. Pinion shall also have significant body housing bearings with O ring seals to prevent premature cycle-life failure. Unit to have dual adjustable travel stops and overtravel in both directions. Fasteners and hardware to be stainless steel. Standard bottom mounting dimensions to conform to ISO5211 and accessory mounting to NAMUR-VDI/VDE guidelines.

TRIAQ Model Number Matrix

- 2** Triac Rack & Pinion Actuator with double travel stops
- T** Triac Rack & Pinion Actuator with single travel stop (discontinued from 40 ~ 3500)

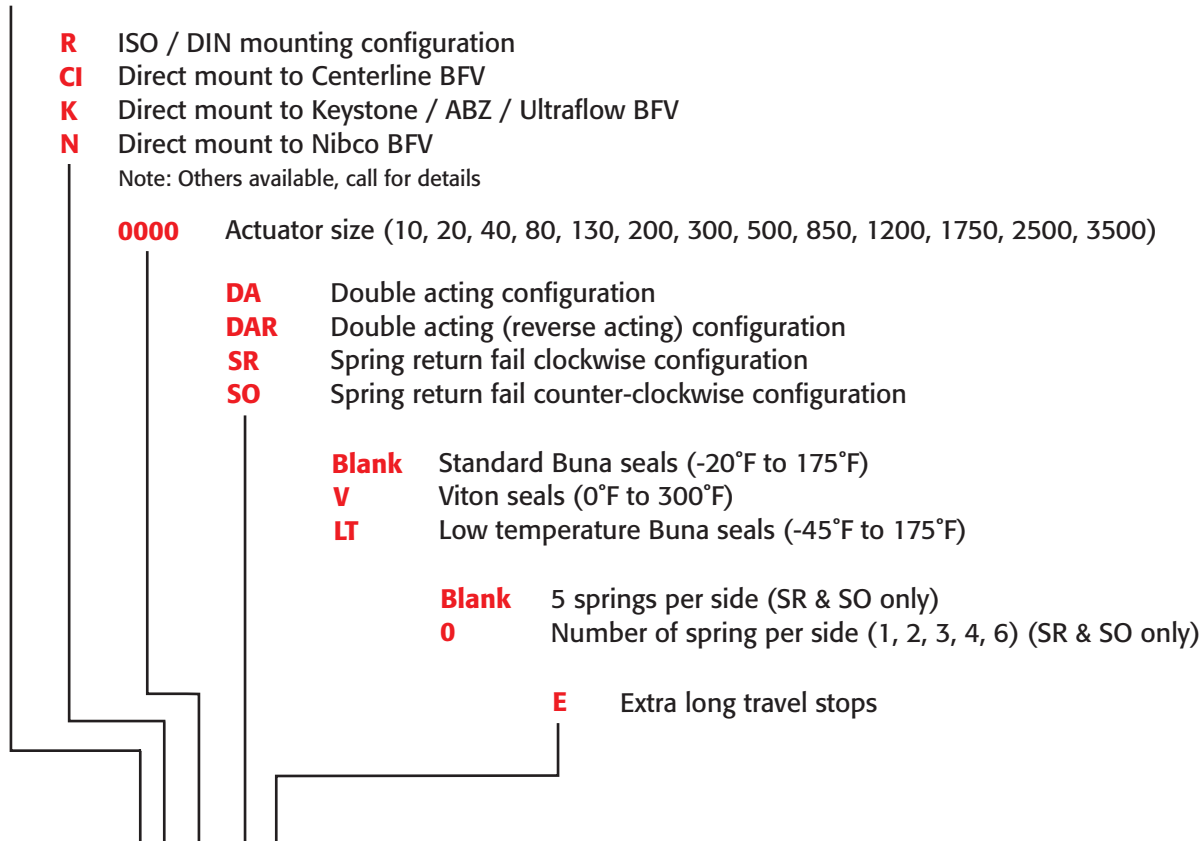

Example: 2R80SRE (Model 80 Rack & Pinion Actuator with Travel Stop in both directions, Spring Return fail clockwise, with Extra long travel stops)

OPERATIONAL DETAILS AND FEATURES



Dual Travel Stop Adjustment

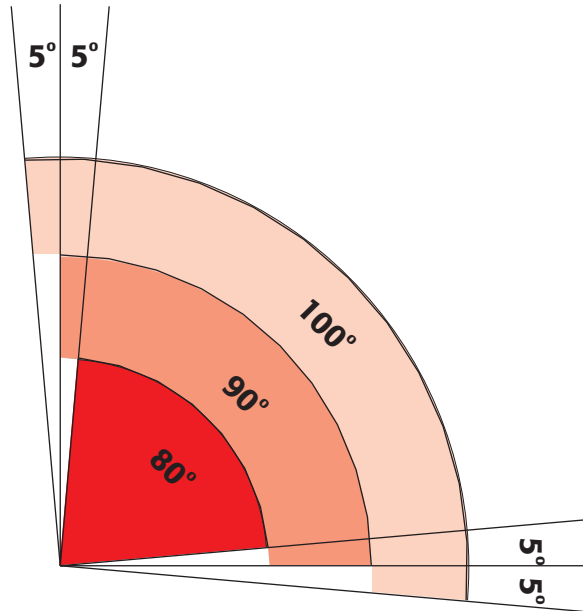
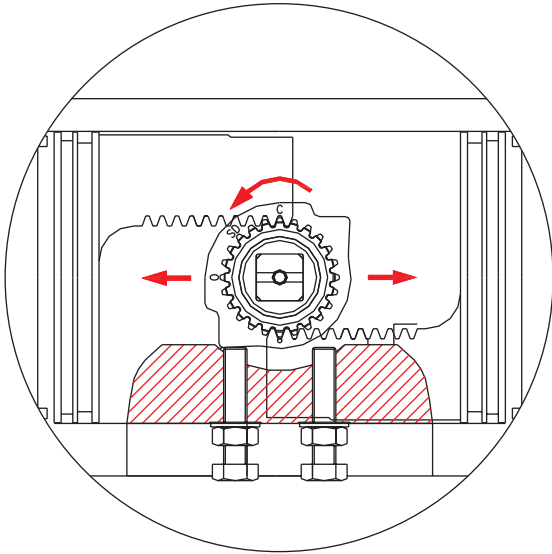

Triac 2R Series features a splined stop collar that provides travel stop adjustments in both the clockwise and counter-clockwise directions. The splined collar ensures minimal hysteresis and repeatable stop positions.

Support

Engineering assistance and AUTOCAD® drawings available

Dimensions						
Actuator	Actuator					Positioner
	A	B	C	D	E	
2R20	2.76	3.64	5.64	4.03	1/8	8.45
2R40	3.43	3.37	5.64	3.76	1/8	5.12
2R80	4.42	9.22	5.64	4.31	1/4	10.18
2R130	4.88	10.73	5.64	5.72	1/4	10.58
2R200	5.28	11.10	5.64	5.49	1/4	10.57
2R300	6.18	13.03	5.91	6.52	1/4	11.85
2R500	6.92	14.78	6.50	7.38	1/4	13.01
2R850	7.91	16.57	6.89	9.78	1/4	14.00
2R1200	9.17	21.50	7.60	12.75	1/4	15.28
2R1750	10.12	23.15	8.31	11.55	1/4	16.20

THE DESIGN AND DISCLOSURE CONTAINED IN THIS DRAWING WAS ORIGINATED BY, AND IS EXCLUSIVE PROPERTY OF A-T CONTROLS, INC.

TRIAC		Division of A-T Controls 11363 Deerfield Road Cincinnati, Ohio 45242 Phone: (513) 247-5465 Fax: (513) 247-5462	BAG	BM	0724102	0724202	TO5511
TRIAC 2R SERIES RACK AND PINION ACTUATOR OR WITH PRR POSITIONER							

THE DESIGN AND DISCLOSURE CONTAINED IN THIS DRAWING WAS ORIGINATED BY, AND IS EXCLUSIVE PROPERTY OF A-T CONTROLS, INC.

TRIAC		Division of A-T Controls 11363 Deerfield Road Cincinnati, Ohio 45242 Phone: (513) 247-5465 Fax: (513) 247-5462	BAG	BM	0810802	0809052	TO5551
TRIAC 2R 1750R RACK AND PINION ACTUATOR WITH TWIST SET TS-V3-2 LIMIT SWITCH, TRIAC TVCS-X411-IN-A120 SOLENOID BLOCK AND BLEED, TRIAC DDG-6 WORM GEAR WITH HANDWHEEL, TRIAC FR-100 FILTER REGULATOR							

EXPLODED VIEW AND BILL OF MATERIAL

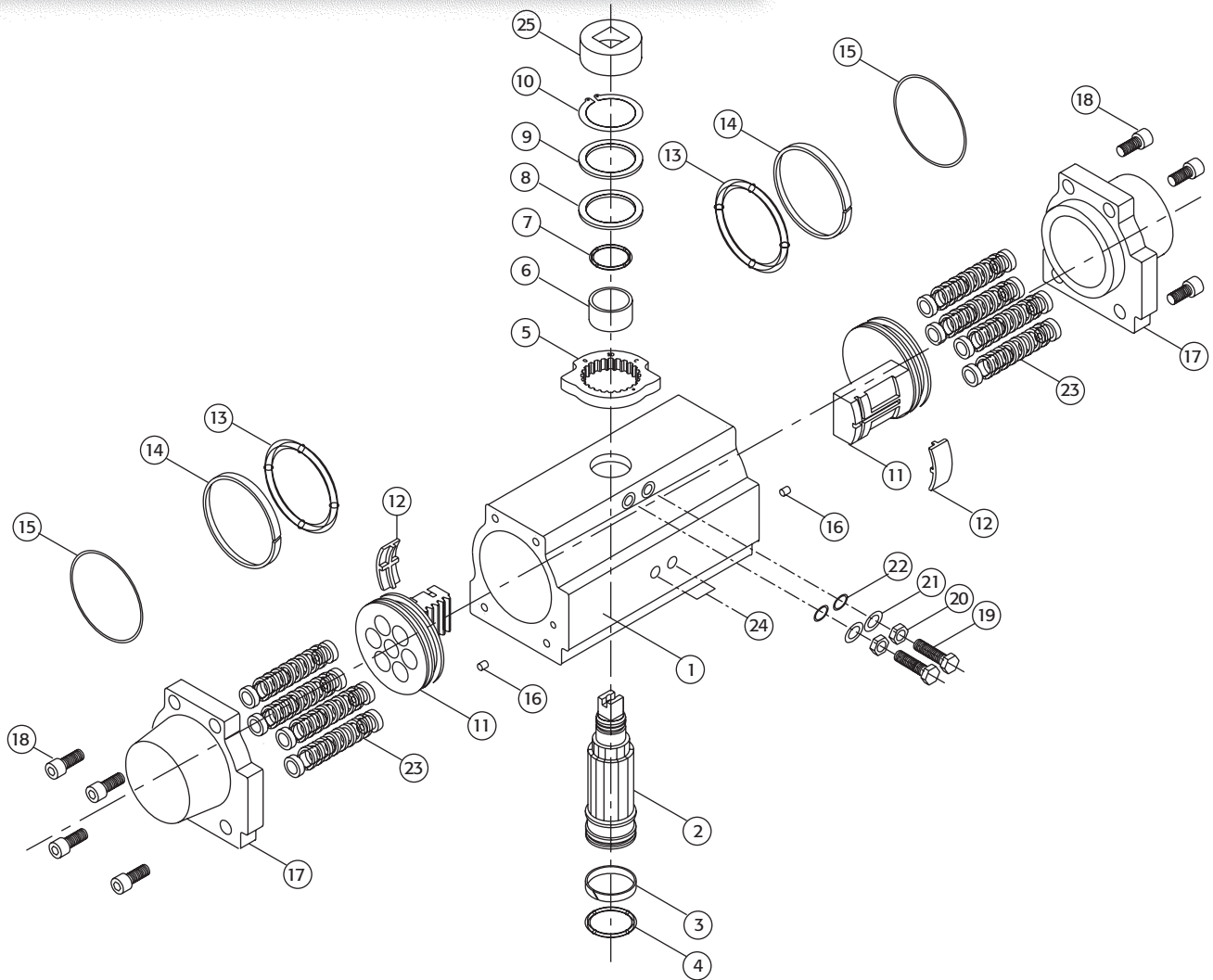

No.	Description	Qty.	Material	Remarks
1	Cylinder Body	1	Aluminum	Hard Anodized
2	Pinion	1	Steel	Electroless Nickel Plated
3	Bottom Pinion Bushing ①②	1	Nylon	
4	Bottom Pinion O-ring ①②	1	Nitrile Buna	
5	Travel Stop Cam	1	SCM21	Phosphate Coated
6	Top Pinion Bushing ①②	1	Nylon	
7	Top Pinion O-ring ①②③	1	Nitrile Buna	
8	Pinion Teflon Washer ①②	1	RTFE	
9	Pinion SST Washer ①②	1	304 Stainless Steel	
10	Snap Ring ①②	1	Steel	Electroless Nickel Plated
11	Piston	2	Die Cast Aluminum	Dichromate Dipped
12	Guide Plate ①②	2	Nylon	
13	Piston O-ring ①②③	2	Nitrile Buna	
14	Piston Guide Band ①②	2	PTFE	
15	End Cap O-ring ①②③	2	Nitrile Buna	
16	Hole Sealant	2	Nitrile Buna	
17	End Cap	2	Die Cast Aluminum	Epoxy Coated
18	End Cap Bolt	2	304 Stainless Steel	
19	Travel Stop Bolt	2	304 Stainless Steel	
20	Travel Stop Nut	2	304 Stainless Steel	
21	Travel Stop Washer	2	304 Stainless Steel	
22	Travel Stop O-ring ①②③	2	Nitrile Buna	
23	Spring Cartridge	12	Spring Steel	Epoxy Coated
24	Dust Plug	2	Polyethylene	
25	Position Indicator	1	Polyethylene	

Repair Kit		
Nitrile Buna	2RKB(Actuator Size)	-20°F ~ +175°F
Viton	2RKV(Actuator Size)	0°F ~ +300°F
Low Temp Buna	2RKL(Actuator Size)	-45°F ~ +175°F

Example: 2RKB0130 = Nitrile Buna Repair Kit for 2R130

Seal Kit		
Nitrile Buna	2BOK(Actuator Size)	-20°F ~ +175°F
Viton	2VOK(Actuator Size)	0°F ~ +300°F
Low Temp Buna	2LTOK(Actuator Size)	-45°F ~ +175°F

Example: 2VOK0080 = Viton Seal Kit for 2R80

- ① Recommended spare parts
- ② Parts included in a repair kit
- ③ Parts included in a seal kit

TRIAQ
Electric Actuators



- ▶ Torques to 30,000 in. lbs.
- ▶ Weatherproof enclosure
- ▶ ISO5211 mounting kits
- ▶ On-off or modulating
- ▶ CSA approved

*Custom Mounting and
Assembly Service*

TRIAQ
Heavy Duty Actuators



- ▶ Double acting
- ▶ Spring return
- ▶ Features stabilizer bar for longer cycle life
- ▶ Torques to 250,000 in. lbs.
- ▶ Easy accessory mounting

AT
**Manual Gear Operators
& Overrides**



- ▶ Quarter turn and multiturn
- ▶ Torques to 106,000 in. lbs.
- ▶ Declutchable gear overrides
- ▶ ISO 5211 and other mounting
- ▶ Custom mounting available

TRIAQ
**Automated Ball Valve
Assemblies**

- ▶ Pneumatic or electric
- ▶ Pre-engineered assemblies
- ▶ Pre-sized and pre-priced
- ▶ Double acting or spring return
- ▶ 150 lb. and 300 lb. flanged
- ▶ 3 piece valves
- ▶ 3-way flanged and threaded
- ▶ Firesafe valves and more
- ▶ Sanitary ends
- ▶ Tank bottom valves





Complete Valve Automation

TRIA

DIVISION OF



A-T Controls, Inc.

11363 Deerfield Rd.
Cincinnati, Ohio 45242

(513) 247-5465

FAX (513) 247-5462

e-mail: sales@a-tcontrols.com

Web site: www.a-tcontrols.com