

## Table of contents

---

	Page
Safety notes/ Technical support	2
-----	
Introduction	3
-----	
Dimensions	4
-----	
Options	5
-----	
Technical data	6
-----	
Mounting	9
-----	
Electrical installation	12
-----	
Programming	14
-----	
Trouble shooting	18
-----	
Menu structure	20
-----	
Maintenance	22
-----	
Notes for use in Hazardous Locations	23
-----	
Disposal	25

Subject to technical change.  
All dimensions in mm (inches).

We assume no liability for typing errors.  
Different variations to those specified are possible.  
Please contact our technical consultants.

## Safety notes / Technical support

---

### Notes

- Installation, maintenance and commissioning must be carried out only by qualified technical personnel.
- The product must be used only in the manner outlined in this instruction manual.

Special attention must be paid to warnings and notes as follows:



#### WARNING

Relates to a caution symbol on the product and means, that a failure to observe the necessary precautions can result in death, serious injury and/ or considerable material damage.



#### WARNING

Relates to a caution symbol on the product: Risk of electric shock



#### WARNING

Used when there is no corresponding caution symbol on the product, means that failure to observe the necessary precautions can result in death, serious injury, and/ or considerable material damage.

#### CAUTION

A failure to observe the necessary precautions can result in considerable material damage.

### Safety symbols

In manual and on product

Description



CAUTION: refer to related documents (manual) for details.



Earth (ground) Terminal



Protective Conductor Terminal

### Technical support

Please contact your local supplier (see [www.uwt.de](http://www.uwt.de) for address). Otherwise you can contact:

UWT GmbH  
 Westendstr. 5  
 87488 Betzigau  
 Germany

Tel. 0049 (0)831 57123-0  
 Fax. 0049 (0)831 76879  
[info@uwt.de](mailto:info@uwt.de)  
[www.uwt.de](http://www.uwt.de)

## Introduction

---

NivoRadar® is a 2-wire, 78 GHz FMCW radar level transmitter for continuous monitoring of solids and liquids in silos and vessels.

## Applications

Ideal system for all solids applications, including those with extreme dust and high temperatures to +200°C (+392°F).

- Powder, granulate, small or coarse bulk goods

Available for industries such as

- Food
- Grain
- Cement
- Plastics
- others

## Function

The main benefits of using 78 GHz over devices using lower frequency are:

- Very narrow beam, so device is insensitive to mounting nozzle interference and vessel obstructions.
- Short wavelength yields very good reflection properties on sloped solids, thus a safe measurement is ensured.

The technology is very tolerant to buildup on the lens antenna, however an air purge inlet is provided for periodic cleaning if required. Signals are processed using Process Intelligence which has been field-proven in over 1,000,000 applications worldwide (ultrasonic and radar).

## Features

### Measurement range

- Up to 100 m (329 ft)

### Approvals

- Approval for use in both General and Hazardous Locations.

### Mechanic

- Lens antenna and flange for quick and easy positioning.
- Stainless steel housing.
- Plane flanges and Aiming flanges.

### Service

- Plug and play system, simple installation and commissioning.

### Programming

- Configure via optional Plug on Display with push buttons.  
Configuration with only 6 parameters.  
Once programmed, the Plug on Display can be removed if desired and used to copy parameters to multiple units.
- Alternative configuration via HART possible.

## Dimensions

### Plane flange version

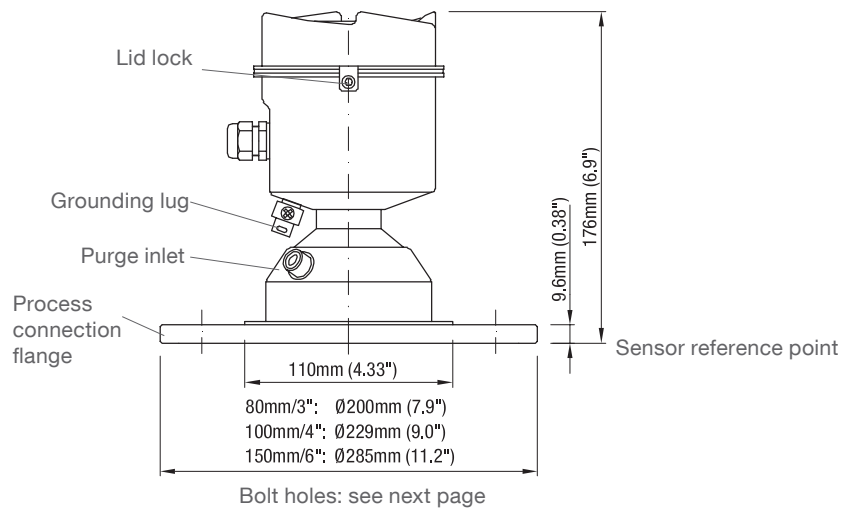

### Easy Aimer flange version 80 mm/ 3"

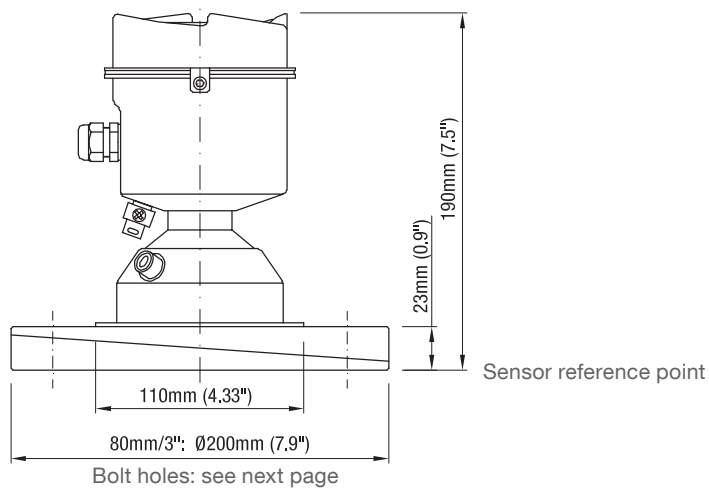

### Easy Aimer flange version 100 mm/ 4" 150 mm/ 6"

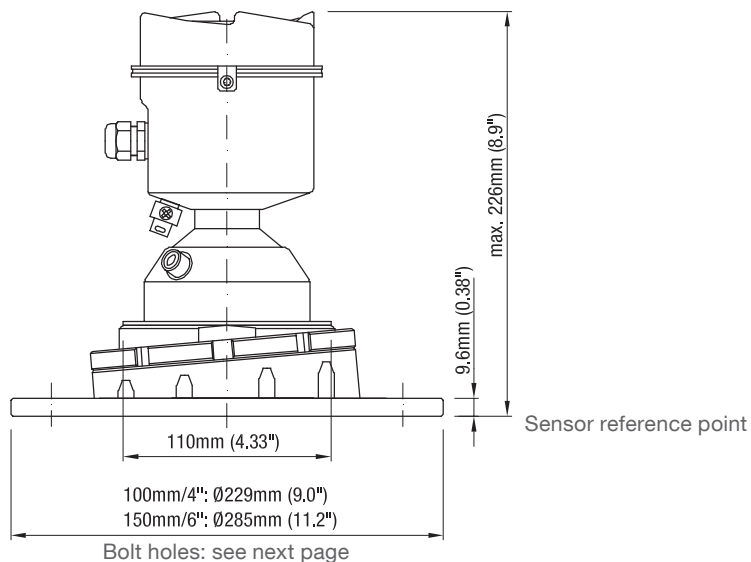

## Dimensions / Options

### Flanges

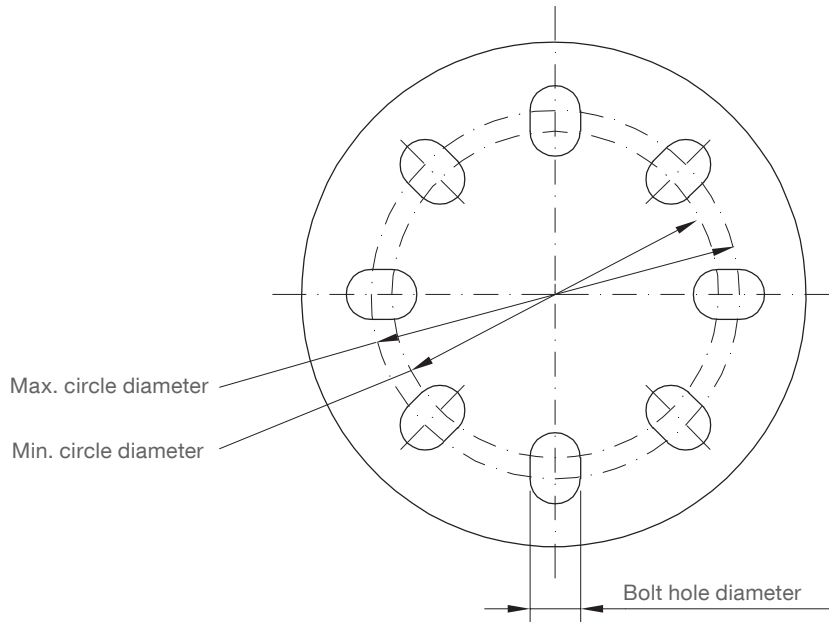

Universal flange (plane flange and Easy Aimer flange) mates with bolt hole pattern of:  
 EN 1092-1 (PN16)  
 ASME B16.5 (150 lb)  
 JIS 2220 (10K)

Pipe size	Max. circle diameter	Min. circle diameter	Bolt hole diameter	Number of bolt holes
80 mm/ 3"	160 mm (6.30")	150 mm (5.91")	19.3 mm (0.76")	8
100 mm/ 4"	191 mm (7.52")	175 mm (6.89")	19.3 mm (0.76")	8
150 mm/ 6"	242 mm (9.53")	240 mm (9.45")	23 mm (0.90")	8

## Options

### Sun protection cover

If the unit is used outdoors, the use of the sun protection cover is recommended. It protects the device from excessively high temperatures.

Material: Stainless steel 1.4301 (304)

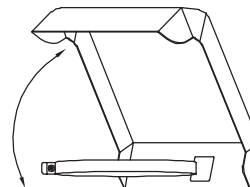

### Mounting kits

Sealings, screws and washers for mounting the unit on a flange

## Technical data

---

### Electrical data

<b>Power supply</b>	4-20 mA loop power Nominal 24 V DC (16.5 .. 30 V DC)									
<b>4-20 mA output</b>	Accuracy ±0.02 mA  Upper limit 20 to 22.6 mA adjustable Lower limit 3.56 to 4 mA adjustable Fail signal 3.56 mA to 22.6 mA; or last value									
<b>Max. loop resistance</b>	<table border="1"> <thead> <tr> <th>Loop voltage</th> <th>Max. loop resistance</th> </tr> </thead> <tbody> <tr> <td>16.5 V</td> <td>250 Ohm</td> </tr> <tr> <td>24 V</td> <td>550 Ohm</td> </tr> <tr> <td>30 V</td> <td>800 Ohm</td> </tr> </tbody> </table>	Loop voltage	Max. loop resistance	16.5 V	250 Ohm	24 V	550 Ohm	30 V	800 Ohm	
Loop voltage	Max. loop resistance									
16.5 V	250 Ohm									
24 V	550 Ohm									
30 V	800 Ohm									
<b>Communication HART</b>	Max. line length: multi-wire: ≤1,500 m (4,921 ft) (depending on wire type. See <a href="http://www.hartcomm.org">www.hartcomm.org</a> for more details)  Protocol HART, Version 6.0									
<b>Memory</b>	Non-volatile EEPROM (no battery required)									
<b>Connection terminals</b>	0.34 .. 2.5 mm <sup>2</sup> (AWG 22 .. 14)									
<b>Cable entry</b>	1 piece M20 x 1.5 or ½" NPT									
<b>Plug on display (inside housing)</b>	Removeable graphic LCD, with bar graph representing level. Display quality will be degraded in temperatures below -20°C (-4°F) and above +65°C (+149°F).									
<b>Mechanical data</b>										
<b>Ingress protection</b>	Type 4X/NEMA 4X, Type 6/NEMA 6, IP68									
<b>Process connection</b>	<b>Plane flanges:</b> EN 1092-1 (PN16)/ ASME B16.5 (150 lb)/ JIS 2220 (10K) bolt hole pattern 3"/ 80 mm, 4"/ 100 mm, 6"/ 150 mm Stainless steel 316L (1.4404 or 1.4435), or 304  <b>Easy Aimer flanges:</b> EN 1092-1 (PN16)/ ASME B16.5 (150 lb)/ JIS 2220 (10K) bolt hole pattern 3"/ 80 mm, 4"/ 100 mm, 6"/ 150 mm Polyurethane powder-coated cast aluminum									
<b>Enclosure</b>	316L/ 1.4404 stainless steel Lid with window (window material polycarbonate)									
<b>Lens antenna</b>	Material: 40 m version: PEI 100 m version: PEEK									
<b>Air Purge Connection</b>	Female 1/8" NPT fitting Non return valve (option, stainless steel, connection of 6mm tube diameter, opens at ca. 0.5 bar (7.25 psi))									
<b>Weight</b>	3" stainless steel flange model: 3.15 kg (6.94 lb)									

## Technical data

### Operating conditions

**Ambient temperature** -40 .. +80°C (-40 .. +176°F)

**Process temperature**

40 m version:  
 -40°C .. +100°C  
 (-40 .. +121°F)

100 m version:  
 -40°C .. +200°C  
 (-40 .. +392°F)

Observe derating curve

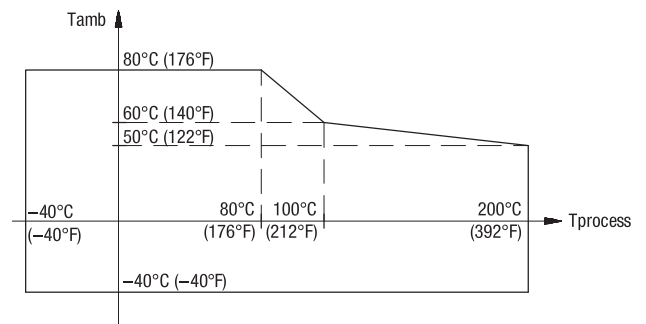

**Process overpressure** Depending on ordered version:  
 -1 .. +0.5 bar (-14.5 .. +7.2 psi)  
 -1 .. +3.0 bar (-14.5 .. +43 psi)

**Ventilation** Ventilation is not required

**Pollution degree** 4

**Installation category** I

**Relative humidity** 0 - 100%, suitable for outdoor

**Altitude** max. 5,000 m (16,404 ft)

### Performance

**Accuracy of measurement** Maximum measured error:  
 5 mm (0.2") including hysteresis and non-repeability. Under severe EMC environments per IEC 61326-1 or NAMUR NE21 the device error may increase to max. 25 mm (1").

Reference conditions:  
 Position Detect (2.7.3.3.) set to Center and Algorithm (2.7.3.1.) set to True First Echo.  
 Measured in accordance with IEC 60770-1:

- ambient temperature +15 to +25°C (+59 to +77°F)
- humidity 45% to 75% relative humidity
- ambient pressure 860 to 1,060 mbar g (86,000 to 106,000 N/m<sup>2</sup> g)

**Frequency/ Beam angle** 78 .. 79 GHz FMCW/ Beam angle 4°

**Max. measurement range** 40 m version: 40 m (131 ft)  
 100 m version: 100 m (328 ft)  
 From sensor reference point

**Min. detectable distance** 400 mm (15.7") from sensor reference point

**Dielectric constant of material measured** For ranges up to 20 m (65.6 ft): min. DK = 1.6  
 For ranges up to 100 m (328 ft): min. DK = 2.5

**Update time** Maximum 10 seconds (Response Rate (2.4.1.) set to FAST)

**Influence of ambient temperature** < 0.003%/ K (average over full temperature range, referenced to maximum range)

## Technical data

### Transport and Storage

**Transport** Observe the instructions as stated on the transport packaging, otherwise the products may get damaged.  
 Transport temperature: -40 .. +80°C (-40 .. +176°F)  
 Transport humidity: 20 .. 85%  
 Transport incoming inspections must be carried out to check for possible transport damage.

**Storage** Products must be stored at a dry and clean place. They must be protected from influence of corrosive environment, vibration and exposure to direct sunlight.  
 Storage temperature: -40 .. +80°C (-40 .. +176°F)  
 Storage humidity: 20 .. 85%

### Approvals

**Hazardous Locations\*** **Dust Ignition Proof:**  
 ATEX II 1D, 1/2D, 2D Ex ta IIIC T139°C Da IP68  
 IEC-Ex ta IIIC T139°C Da IP68  
 FM/ CSA DIP Class II, Div.1, Gr. E, F, G, Class III  
 TR-CU Ex ta IIIC T139°C Da X

**Non-sparking/ Energy Limited:**  
 ATEX II 3G Ex nA II T4 Gc, Ex nL IIC T4 Gc  
 IEC-Ex nA II T4 Gc, nL IIC T4 Gc  
 TR-CU 2Ex nA IIC T4 Gc X

**Non-incendive:**  
 FM/CSA NI Class I, Div.2, Gr. A,B,C,D

**Ordinary Locations\*** CE/ TR-CU  
 FM/ CSA General purpose

**EMC** EN 61326 - 1 (industrial standard)

**RoHS conformity** According to directive 2011/65/EU

**Radio** Radio Equipment Directive (RED) Compliance (Europe)  
 FCC Conformity (US)  
 Industry Canada

**Radio Equipment Directive (RED) Compliance (Europe)**

Hereby, UWT GmbH, declares that the NR 3000 is in compliance with the essential requirements and other relevant provisions of Directive 2014/53/EU.  
 The NR 3000 complies with EN 302 372 for use in closed storage vessels, when installed according to the installation requirements of EN 302 372, and may be used in all EU countries.

For the receiver test that covers the influence of an interferer signal to the device, the performance criterion has at least the following level of performance according to ETSI TS 103 361 [6]:

- Performance criterion: measurement value variation  $\Delta d$  over time during a distance measurement
- Level of performance:  $\Delta d \leq \pm 50$  mm

The NR 3000 complies with EN 302 729 for use outside of closed tanks in EU countries. For open air installations, the following conditions must be observed:

- Installation and maintenance is performed by suitably qualified and trained personnel.
- The NR 3000 shall be installed only in a permanent fixed position pointing downwards. Its location shall comply with the following two restrictions:
  - 1) It shall be installed with a minimum separation distance of 4 km from Radio Astronomy sites listed at [www.craf.eu/radio-observatories-in-europe](http://www.craf.eu/radio-observatories-in-europe) unless special authorization has been provided by the responsible national regulatory authority.
  - 2) If it is installed at a location between 4 and 40 km from any Radio Astronomy site listed at [www.craf.eu/radio-observatories-in-europe](http://www.craf.eu/radio-observatories-in-europe) the NR 3000 shall be installed at a height not exceeding 15 m from the ground.

**FCC Conformity (US)**

US Installations only: Federal Communications Commission (FCC) rules:

WARNING: Changes or modifications not expressly approved by UWT GmbH could void the user's authority to operate the equipment.

Notes:

- This device has been tested and found to comply with the limits Class B digital device part 15 of the FCC Rules. These limits are designed to provide reasonable protection against harmful interference when the equipment is operated in a commercial environment.

\* Depending on selected version in selection list



## Technical data / Mounting

- This device has also been tested and found to comply with the limits §15.256, Subpart C-Intentional radiators, pursuant to Part 15 of the FCC Rules. These limits are designed to provide reasonable protection against harmful interference when the equipment is operated in a commercial environment.
- This device generates, uses, and can radiate radio frequency energy and, if not installed and used in accordance with the instruction manual, may cause harmful interference to radio communications, in which case the user will be required to correct the interference at his/her own expense.
- This device may be used to measure levels in fixed or mobile enclosed tanks.
- This device may be used to measure levels in open air environments or outside enclosed tanks, subject to the following conditions:
  - o Devices shall be installed and maintained to ensure a vertically downward orientation of the transmit antenna's main beam.
  - o Devices shall be installed only at fixed locations. Devices shall not operate while being moved or while inside a moving container.
  - o Hand-held applications and residential use are prohibited.

### Industry Canada

The NR 3000 complies with Industry Canada standard RSS211 (March 2015).

- a) The installation of the NR 3000 shall be done by trained installers, in strict compliance with the manufacturer's instructions.
- b) The use of this device is on a "no-interference, no-protection" basis. That is, the user shall accept operations of high-powered radar in the same frequency band which may interfere with or damage this device. However, devices found to interfere with primary licensing operations will be required to be removed at the user's expense.
- c) The installer/ user of this device shall ensure that it is at least 10 km from the Dominion Astrophysical Radio Observatory (DRAO) near Penticton, British Columbia. The coordinates of the DRAO are latitude 49°19'15" N and longitude 119°37'12" W. For devices not meeting this 10 km separation (e.g., those in the Okanagan Valley, British Columbia,) the installer/ user must coordinate with, and obtain the written concurrence of, the Director of the DRAO before the equipment can be installed or operated. The Director of the DRAO may be contacted at 250-497-2300 (tel.) or 250-497-2355 (fax). (Alternatively, the Manager, Regulatory Standards, Industry Canada, may be contacted.)

## Mounting

### ! General Safety Instructions

<b>Process pressure</b>	<p>Improper installation may result in loss of process pressure.</p> <p>Never attempt to loosen, remove, or disassemble process connection or instrument housing while vessel contents are under pressure.</p>
<b>Chemical resistance against the medium</b>	<p>Materials of construction are chosen based on their chemical compatibility (or inertness) for general purposes. For exposure to specific environments, check with chemical compatibility charts before installing.</p>
<b>Mounting location</b>	<p>The right mounting place is significant for a proper function. Observe mounting instructions.</p>
<b>Sealings</b>	<p>The user is responsible for the selection of bolting and gasket materials which will fall within the limits of the flange and its intended use and which are suitable for the service conditions.</p>

### ! Additional Safety Instructions for Hazardous Locations

<b>Installation regulations</b>	<p>For devices to be used in Hazardous Locations the respective valid installation regulations must be observed.</p>
<b>Electrostatic charge</b>	<p>Parts of the enclosure may be non-conducting and may generate an ignitioncapable level of electrostatic charge under certain extreme conditions. The user should ensure that the equipment is not installed in a location where it may be subjected to external conditions (such as high-pressure steam), which might cause a build-up of electrostatic charge on non-conducting surfaces.</p>

## Mounting

### Mounting instructions

#### Mounting position and aiming

- The unit is mounted vertically on top of the silo.
- Observe enough distance to the wall.
- Avoid central locations on tall, narrow vessels.
- A clear line of sight from the sensor to the product being monitored is required.
- Keep the sensor away from fill pipes, ladders, beams etc.

Aiming is strongly suggested for solid measurement. It helps to optimize the echo signal (mainly for low material level in the cone) and helps to solve not perfect mounting positions.

For proper mounting positions vertical installation without aiming is possible.

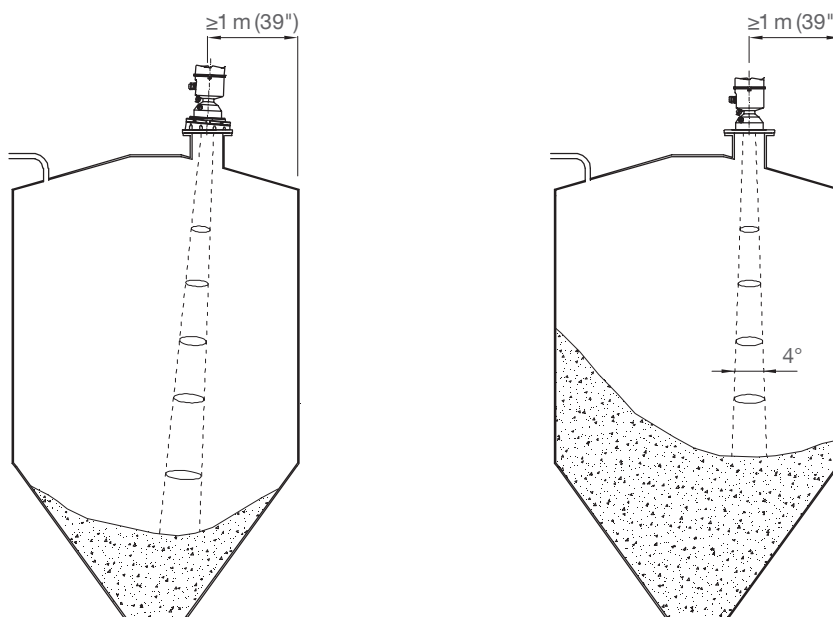

#### Easy Aimer adjustment

1. For the 80 mm/ 3" Easy Aimer flange, tapered split washers with pressure rated versions are provided to keep nuts and bolts perpendicular to the flange surface.

For 100 mm/ 4" and 150 mm/ 6" Easy Aimer flange: Loosen the set screws in the locking ring. Holding the electronics enclosure firmly, loosen the Aimer locking ring using the supplied C spanner, until the unit drops down slightly. The enclosure can then be turned freely.

2. Direct the unit in the desired position and re-tighten the screws.

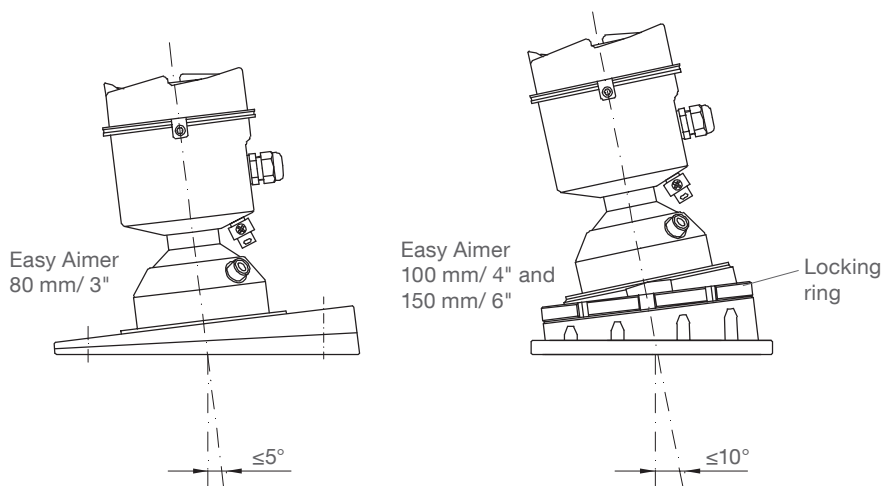

## Mounting

### Air Purging System

#### Use of air purging system

- The purge airflow is designed to create a strong vortex of air that rapidly cleans the face of the lens.
- The air purge system can clean both dust and moisture off the lens.
- It can be used for periodic cleaning.

#### Purge airflow

- The customer will supply the purging air by a manual or automatic valve system.
- Clean, dry air must be provided.
- Recommended 6.2 .. 7.6 bar (90 .. 110 psi) for effective cleaning.
- Air pressure in vessel can affect purge operation.

#### Notes:

- Purge duration, pressure, and interval, will vary with each application. It is the user's responsibility to determine the requirements depending on the application and cleaning required.
- Short duration bursts of high pressure provide more effective cleaning than continuous low pressure air.
- It is the customer's responsibility to ensure that any vacuum or pressure in the measured vessel is maintained, considering the hole that passes through the process connection and the antenna system.

Flow rate versus applied pressure:

Air Pressure	Approx. inlet volume flow rate
1.4 bar (20 psi)	8.1 Nm <sup>3</sup> /h (5 SCFM*)
2.8 bar (40 psi)	16.1 Nm <sup>3</sup> /h (10 SCFM*)
3.4 bar (50 psi)	24.2 Nm <sup>3</sup> /h (15 SCFM*)
5.5 bar (80 psi)	32.2 Nm <sup>3</sup> /h (20 SCFM*)
6.9 bar (100 psi)	40.3 Nm <sup>3</sup> /h (25 SCFM*)
7.6 bar (110 psi)	48.3 Nm <sup>3</sup> /h (30 SCFM*)

\*standard cubic feet per minute

#### Purge Connection

- The purge connection is closed by the manufacturer.
- When the plug is removed to connect a purging system, the operator is responsible for ensuring that the purging circuit conforms to "Ex" requirements, for example, by fitting an NRV valve (non return valve). If applicable use the Non return valve offered by the manufacturer.

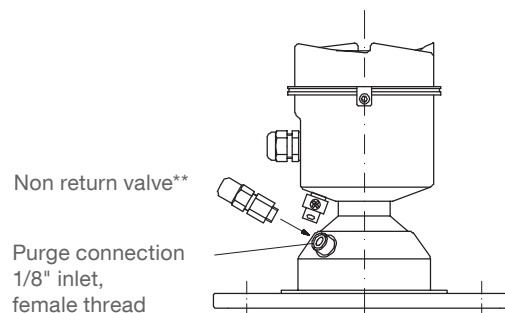

\*\* Non return valve offered by the manufacturer:

- Stainless steel
- Connection of 6 mm tube diameter
- Opens at ca. 0.5 bar (7.25 psi)

## Electrical installation

### ! General Safety Instructions

<b>Handling</b>	In case of improper handling or handling malpractice, the electric safety of the device cannot be guaranteed.
<b>Installation regulations</b>	The local regulations must be observed.
<b>Type plate</b>	Check the type plate on your instrument to verify the approval rating.
<b>Wiring diagram</b>	The electrical connections are made in accordance with the wiring diagram.
<b>Supply voltage</b>	Compare the supply voltage applied with the specifications given on the name plate before switching the device on. The DC input terminals shall be supplied from a source providing electrical isolation between the input and output, in order to meet the applicable safety requirements of IEC 61010-1.
<b>Cable gland</b>	The screwed cable gland and closing element must have following specifications: Ingress protection IP68, temperature range from -40°C to +80°C, certified depending on the country where the unit is installed, pull relief. Make sure that the screwed cable gland safely seals the cable and that it is tight (danger of water intrusion). The diameter of the field wiring cable has to match to the clamping range of the used cable gland.
<b>Conduit system</b>	In case of using a conduit system (with NPT thread) instead of a cable gland the regulations of the country, where the unit is installed, must be observed. The conduit must have a tapered thread NPT ½" in accordance with the unit and ANSI B 1.20.1.
<b>Field wiring cables</b>	Use twisted pair cable. The cross section has to match with the clamping range of the connection terminals. The temperature rating must be in accordance to the ambient temperature.
<b>Guiding and connecting the cable in the terminal box</b>	Cut the field wiring cables to appropriate length to fit properly into the terminal box. Strip the cable jacket for approximately 70 mm (2.75") from the end of the cable, and thread the wires through the gland.

### ! Additional Safety Instructions for Hazardous Locations

#### External equipotential bonding terminal

Connect to equipotential bonding of the plant

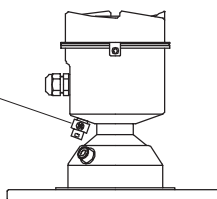

<b>Field wiring</b>	The equipment shall be installed such that the supply cable is protected from mechanical damage. The cable shall not be subjected to tension or torque. The equipment manufacturer is not responsible for providing the supply cable.
<b>Cable glands for Hazardous Locations</b>	The used entry devices and blanking elements must have an adequate type approval (protection concepts type 'n' or increased safety 'e' or protection by enclosure 't') and a temperature range as defined in the technical data of the unit. In addition they shall be suitable for the conditions and correctly installed. Where available the provided original parts of the manufacturer must be used.
<b>Conduit system for Hazardous Locations</b>	In addition the regulations of the country must be observed. The used flameproof seals and blanking elements must have an adequate type approval and a temperature range as defined in the technical data of the unit. In addition they shall be suitable for the conditions and correctly installed. Where available the provided original parts of the manufacturer must be used.
<b>Supply rating</b>	The supply to the equipment shall be rated for a prospective short-circuit current of not more than 10 kA and shall be protected by a suitably-rated fuse.
<b>Further safety notes</b>	See page 23.

## Electrical installation

### 4-20 mA

The terminals are located below the display. To connect the unit, remove the display by gently turning the display a quarter turn counter-clockwise until it is free.

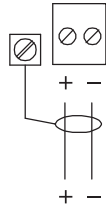

Use twisted pair cable: 0.34 mm<sup>2</sup> to 2.5 mm<sup>2</sup> (AWG 22 to 14)  
 Connect cable shield to ground terminal

24 V DC/ 4-20 mA loop

### 4-20 mA HART

Typical PLC/ mA configuration with HART:

- Depending on the system design, the power supply may be separate from the PLC, or integral to it.
- HART resistance (total loop resistance, that is, cable resistance plus 250 Ohm (external resistor) must be less than 550 Ohm @24 V supply for the device to function properly.
- The external resistor is not required, if the PLC has an integral 250 Ohm resistor.

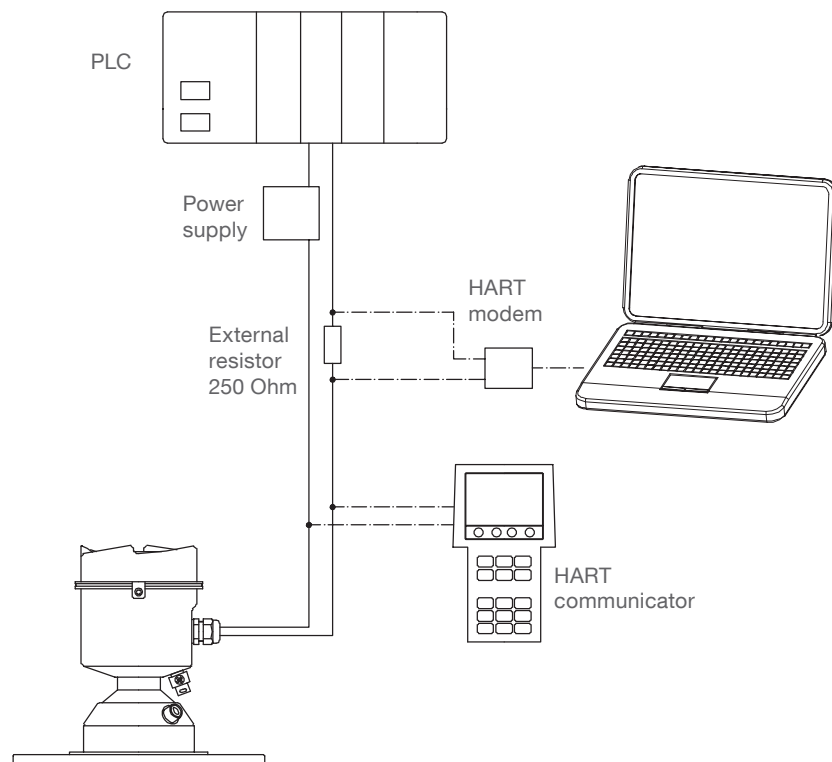

## Programming

### Overview

#### Plug on display

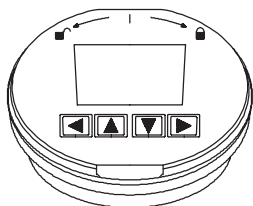

Programming is done with the "Plug on display".

The first time the device is configured, you will be prompted to select a language (English, German, French, Spanish or Chinese). Select language with ▼ and confirm by pressing ►.

#### Measurement mode

After power up the unit goes to Measurement mode. The required time to first measurement is less than 50 seconds.

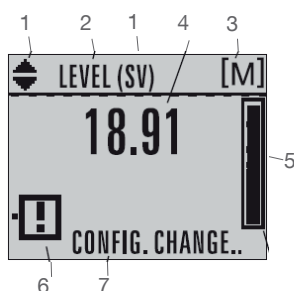

#### Normal operation:

- 1 Not relevant\*
- 2 Selected operation: level, space, or distance.
- 3 Selected units: m, cm, mm, ft, in.
- 4 Actual measured value (according to selected items 2 and 3).
- 5 Bar graph indicates level.
- 6 Device status indicator.
- 7 Device status text messages.

\* Relevant with advanced programming. Toggle indicator for PV or SV (primary or secondary values). PV values represent the 4-20 mA output (considering a programmed linearisation), SV values represent the pure measured values (without linearisation). Press ▲ ▼ to switch.



#### In case of fault:

- 6 Service required icon appears.
- 7 Text area displays a fault code and an error message.

#### Program mode

##### Display view

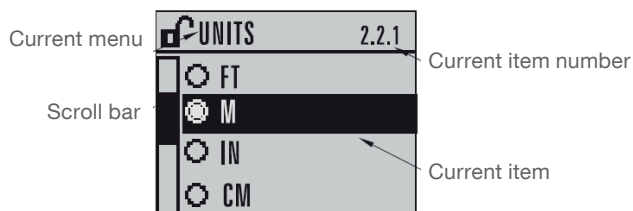

#### General procedure modify digits

Note: When the Enter icon is highlighted, press ▲ to insert a digit on the right, ▼ to delete the right-most digit, ► to accept the value, or ◀ to cancel.

1. Navigate to the parameter you wish to modify and press ► to edit it. The value will be highlighted.
2. Press ▲ or ▼ to delete the highlighted value, or ◀ to modify the value from the left-most digit, starting with the plus/ minus sign.
3. With the plus or minus sign highlighted, press ▲ or ▼ to change it. Press ► to highlight the next digit to the right.
4. Use ▲ or ▼ to modify the highlighted digit. Scroll past 9 to reach the decimal point.
5. When the value is complete, press ► until the Enter icon is highlighted, then press ► to accept the value.

#### To modify a text string

1. Navigate to the parameter you wish to modify and press ► to edit it. The string will be highlighted.
2. Follow the same steps as above, to add, delete, or modify characters.

## Programming

### Quick Start

In Measurement mode press **▶** to enter Program mode.  
 Choose Quick Start (1.), and then press **▶** to enter Quick Start Wizard (1.1).  
 Press **▼** to jump to first Quick Start item "Vessel".

#### Vessel

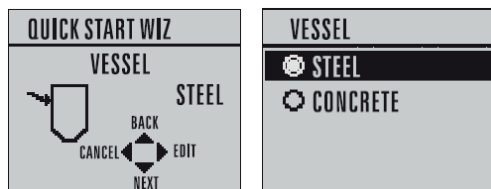

Select vessel construction material.

Options:  
 Steel \*  
 Concrete

#### Response Rate

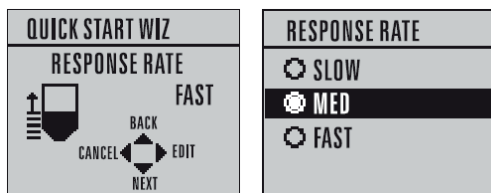

Sets the reaction speed of the device to measurement changes in the target range.

Response Rate	Vessel Fill Rate or Empty Rate
SLOW	0.1 m/min (0.32 ft/min)
MED *	1.0 m/min (3.28 ft/min)
FAST	10.0 m/min (32.8 ft/min)

Use a setting just faster than the maximum vessel filling or vessel emptying rate (whichever is greater).

#### Units

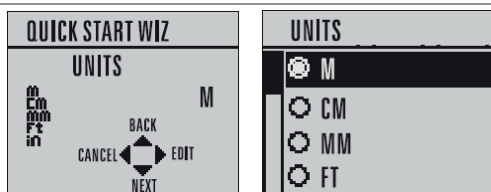

Sensor measurement units shown on the display.

Options:  
 m \*, cm, mm, ft, in

#### Operation

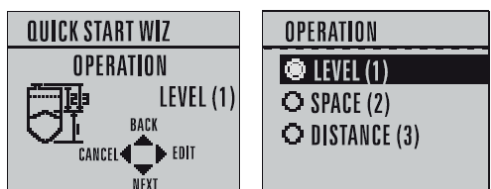

Operation	Description
LEVEL (1) *	Distance from Low Calibration Point to material surface
SPACE (2)	Distance from High Calibration Point to material surface
DISTANCE(3)	Distance from Sensor Reference Point to material surface

The 4-20 mA output will be set accordingly, see drawing on next page.

#### Low calibration point

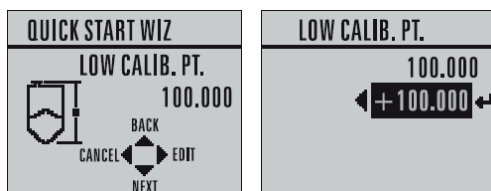

Distance from Sensor Reference Point to Low Calibration Point: usually process empty level.

Values Range: 0 to 40 m/100 m.

See drawing on next page.

#### High calibration point

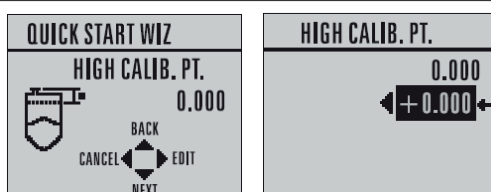

Distance from Sensor Reference Point to High Calibration Point: usually process full level.

Values Range: 0 to 40 m/100 m.

See drawing on next page.

To transfer Quick Start values to the device and return to Program menu, press **▼** (Finish).  
 To ensure a safe measurement, go to page 17, "Check for safe measurement using echo profile"

\* Factory setted values

## Programming

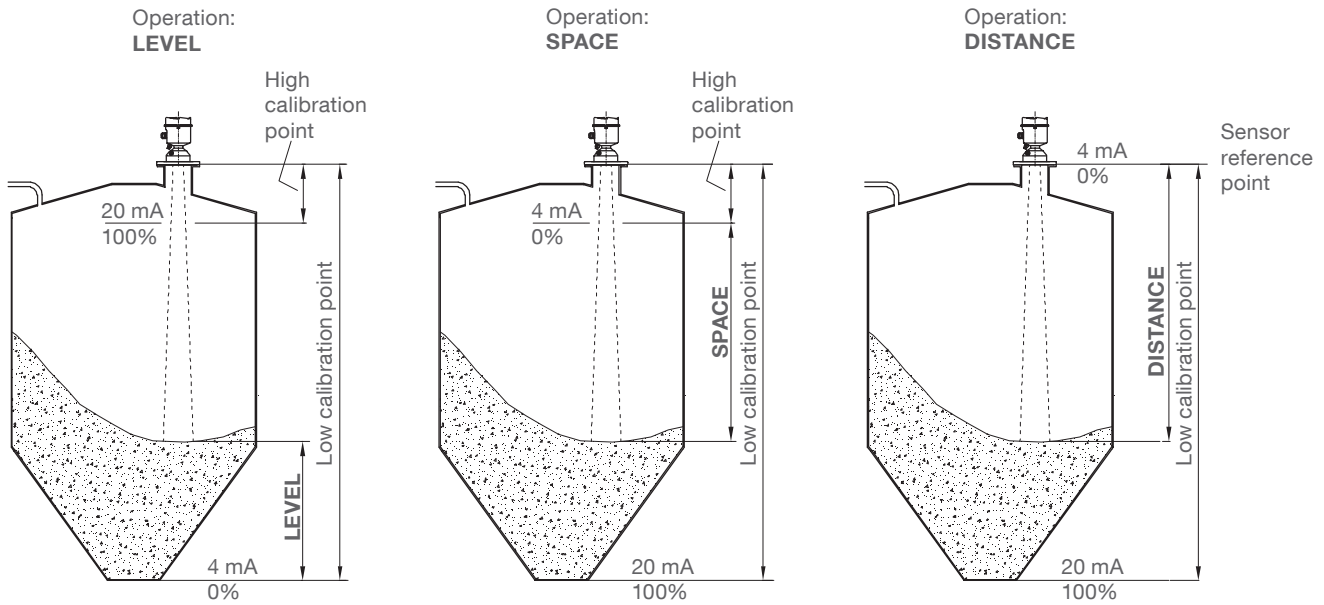



## Programming

### Check for safe measurement using echo profile

In Measurement mode press **▶** to enter Program mode.  
 Choose Diagnostics (3.), and then Echo Profile (3.2.)  
 Press **▶** to request a profile.

#### Displayed echo profile

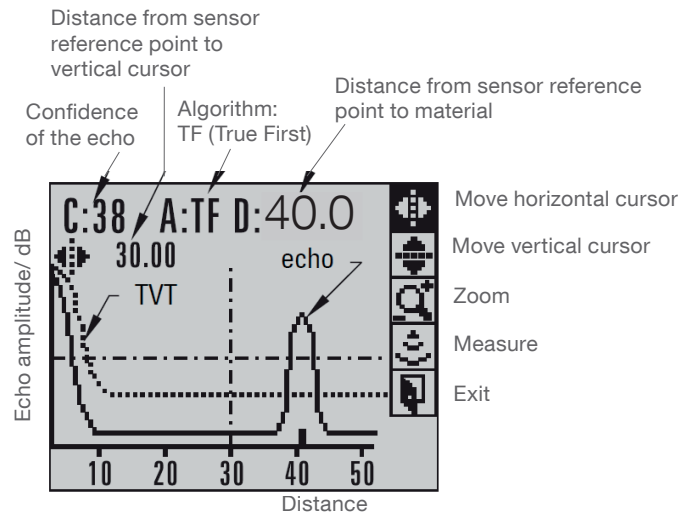

- Distance from sensor reference point to vertical cursor:  
Allows to measure the exact distance of an echo.
- Algorithm TF (True First):  
Standard setting. The first echo which is bigger than the TVT curve is considered as material level.
- Distance from sensor reference point to material:  
Distance of the echo considered as material level.

#### To navigate in the echo profile

Use **▲** or **▼** to scroll to an icon. When an icon is highlighted, that feature becomes active.

To move a cursor, press **▶** to increase the value, **◀** to decrease.

To Zoom into an area, position the intersection of the cursor at the center of that area, select Zoom, and press **▶**. Press **◀** to Zoom out.

To update the profile, select Measure and press **▶**.

#### Checking the echo profile

Following items can easily be checked:

- Confidence of the echo needs to be  $\geq 5$ . If the value is smaller, the echo is too weak.
- Echoes in front of the material level echo need to be significant below the TVT curve. If an echo is present which is bigger than the TVT curve, it is considered as material level and causes a wrong measurement.

Possible improvements:

Check for proper mounting position (see chapter Mounting).

Check if sensor aiming helps to decrease such an echo (see chapter Mounting).

If no improvement is possible, contact manufacturer.

#### Return to Measurement mode

To return to the previous menu, select Exit, then press **▶**, then press **◀** to return to Measurement mode.

## Programming / Trouble shooting

### Copy of programmed parameters to other devices

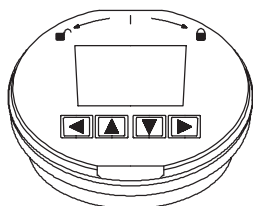

After a device is programmed, the parameters can be copied to others devices by loading the parameters into the "Plug on display", then remove the display from the device, insert it on another device and load the parameters into this device.

#### Copy parameters to "Plug on display"

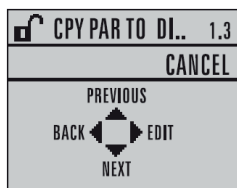

In Measurement mode press **▶** to enter Program mode.  
 Choose Quick Start (1.), then CPY PAR TO DI (1.3). Press **▶**, then select START and press **▶**. PARAM UPLOAD is displayed, then the device returns to Measurement mode.

#### Copy parameters from "Plug on display" to a unit

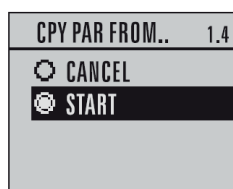
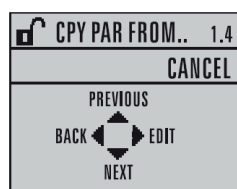

In Measurement mode press **▶** to enter Program mode.  
 Choose Quick Start (1.), then CPY PAR FROM (1.4). Press **▶**, then select START and press **▶**. PARAM DOWNLOAD is displayed, then the device returns to Measurement mode.

### Advanced programming and FDT (Pactware)

This is not part of this manual. Please refer to manufacturer for more information.

### Trouble shooting

Failure description	Possible reason	Solution
Value jumps during measurement to 100% (indicating full vessel).	Reflections from mounting (e.g. socket)	<p>Ensure that at least 1.5 m distance from sensor reference point to material level is present.</p> <p>In Measurement mode press <b>▶</b> to enter Program mode.</p> <p>Select SETUP (2.), TVT SETUP (2.8), AUTO ECHO SUPP (2.8.1) Go to LEARN and press <b>▶</b>.</p> <p>The units states LEARN for some seconds. During this time echoes up to 1.0 m distance are measured and as wrong echoes ignored.</p> <p>When the unit states ON, you can go back to measurement mode by pressing several times <b>◀</b>.</p>

## Fault codes

Code	Meaning	Corrective action
S: 0	The device was unable to get a measurement within the Fail-safe LOE Timer period. Possible causes: faulty installation, antenna material buildup, foaming/ other adverse process conditions, invalid configuration range.	<ul style="list-style-type: none"> <li>• Ensure installation details are correct.</li> <li>• Ensure no antenna material buildup. Clean if necessary.</li> <li>• Adjust process conditions to minimize foam or other adverse conditions.</li> <li>• Correct configuration range.</li> <li>• If fault persists, contact your local representative.</li> </ul>
S: 3	Device is nearing its lifetime limit according to the value set in Maintenance Required Limit.	Replacement is recommended.
S: 4	Device is nearing its lifetime limit according to the value set in Maintenance Demanded Limit.	Replacement is recommended.
S: 6	Sensor is nearing its lifetime limit according to the value set in Maintenance Required Limit.	Replacement is recommended.
S: 7	Sensor is nearing its lifetime limit according to the value set in Maintenance Demanded Limit.	Replacement is recommended.
S: 8	Service interval as defined in Maintenance Required Limit has expired.	Perform service.
S: 9	Service interval as defined in Maintenance Demanded Limit has expired.	Perform service.
S: 12	Internal temperature of device has exceeded specifications: it is operating outside its temperature range.	<ul style="list-style-type: none"> <li>• Relocate device and/ or lower process temperature enough to cool device.</li> <li>• Inspect for heat-related damage and contact your local representative if repair is required.</li> <li>• Fault code will persist until a manual reset is performed.</li> </ul>
S: 17	Calibration interval as defined in Maintenance Required Limit has expired.	Perform calibration.
S: 18	Calibration interval as defined in Maintenance Demanded Limit has expired.	Perform calibration.
S: 25	Internal error.	Reset power. If fault persists, contact your local representative.
S: 48	User configuration is invalid. One or more of parameters: Low Calibration Point, High Calibration Point, Volume breakpoints, and/ or Auto False-Echo Suppression, are set to invalid values.	<ul style="list-style-type: none"> <li>• Reconfigure the unit.</li> <li>• Ensure the difference between High Calibration Point and Low Calibration Point is not less than or equal to zero; do a Master Reset.</li> </ul>
S: 52	Fail-safe is activated. Possible causes: 1. hardware failure 2. memory failure 3. Fail-safe LOE timer expired– possible causes: faulty installation, antenna material buildup, foaming/ other adverse process conditions, invalid calibration range.	For 3: <ul style="list-style-type: none"> <li>• Correct configuration; ensure installation is correct;</li> <li>• no antenna buildup;</li> <li>• adjust process conditions to minimize foaming/ other adverse conditions;</li> <li>• correct calibration range.</li> </ul> If fault persists, or for 1 and 2, contact your local representative.
S: 54	Fault occurs when the PV exceeds the user configured min./ max. range for mA output.	Adjust process to fall within limits of min./ max. mA values or adjust limits of mA if possible.
S: 94	Device error. Possible causes: 1. Voltage low at the NR 3000 2. Hardware defect	For 1: Confirm voltage is within specifications and modify wiring or increase source voltage accordingly. For 2: Repair required: contact your local representative.
other codes		Contact your local representative.

## Menu structure

---

### Menu structure

#### 1. WIZARDS

- 1.1 QUICK START WIZ
  - VESSEL
  - RESPONSE RATE
  - UNITS
  - OPERATION
  - LOW CALIB. PT.
  - HIGH CALIB. PT.
- 1.2 AFES WIZ
- 1.3 COPY PARAMETERS TO DISPLAY
- 1.4 COPY PARAMETERS FROM DISPLAY
- 1.5 COPY FIRMWARE TO DISPLAY
- 1.6 COPY FIRMWARE FROM DISPLAY

#### 2. SETUP

- 2.1 DEVICE
  - 2.1.1 LONG TAG
  - 2.1.2 TAG
  - 2.1.3 DESCRIPTOR
  - 2.1.4 MESSAGE
  - 2.1.5 INSTAL DATE
  - 2.1.6 HARDWARE REV
  - 2.1.7 FIRMWARE REV
  - 2.1.8 LOADER REV
  - 2.1.9 MENU TIMEOUT
  - 2.1.10 MANUF. DATE
- 2.2 SENSOR
  - 2.2.1 UNITS
  - 2.2.2 SENSOR MODE
  - 2.2.3 DAMPING FILTER
  - 2.2.4 TEMP. UNITS
  - 2.2.5 UNIT
- 2.3 CALIBRATION
  - 2.3.1 LOW CALIB. PT.
  - 2.3.2 HIGH CALIB. PT.
  - 2.3.3 SENSOR OFFSET
- 2.4 RATE
  - 2.4.1 RESPONSE RATE
  - 2.4.2 FILL RATE/MIN
  - 2.4.3 EMPTY RATE/MIN
- 2.5 FAIL-SAFE
  - 2.5.1 MAT. LEV
  - 2.5.2 TIMER
  - 2.5.3 LEVEL
- 2.6 ANALOG OUTPUT SCALE
  - 2.6.1 CURRENT OUTPUT FUNCTION
  - 2.6.2 4 MA SETPOINT
  - 2.6.3 20 MA SETPOINT
  - 2.6.4 MIN MA LIMIT
  - 2.6.5 MAX MA LIMIT
  - 2.6.6 MA OUTPUT MODE
  - 2.6.7 MANUAL VALUE
  - 2.6.8 MA OUTPUT VALUE
- 2.7 SIGNAL PROCESSING
  - 2.7.1 NEAR RANGE
  - 2.7.2 FAR RANGE

- 2.7.3 ECHO SELECT
  - 2.7.3.1 ALGORITHM
  - 2.7.3.2 ECHO THRESHOLD
  - 2.7.3.3 POSITION DETECT
  - 2.7.3.4 CLEF RANGE
  - 2.7.3.5 ECHO MARKER
- 2.7.4 SAMPLING
  - 2.7.4.1 ECHO LOCK
  - 2.7.4.2 UP SAMP.
  - 2.7.4.3 DOWN SAMP.
  - 2.7.4.4 ECHO LOCK WINDOW
- 2.7.5 FILTERING
  - 2.7.5.1 NARROW ECHO FILTER
  - 2.7.5.2 REFORM ECHO
  - 2.7.5.3 AVG AMOUNT
- 2.7.6 ECHO QUALITY
  - 2.7.6.1 CONFIDENCE
  - 2.7.6.2 ECHO STRENGTH

#### 2.8 TVT SETUP

- 2.8.1 AUTO ECHO SUPP
- 2.8.2 AUTO SUPP RANGE
- 2.8.3 HOVER LEVEL
- 2.8.4 SHAPER MODE

#### 2.9 TVT SHAPER

- 2.9.1 BREAKPOINT 1-9
- 2.9.2 BREAKPOINT 10-18
- 2.9.3 BREAKPOINT 19-27
- 2.9.4 BREAKPOINT 28-36
- 2.9.5 BREAKPOINT 37-45
- 2.9.6 BREAKPOINT 46-54
- 2.9.7 BREAKPOINT 55-63
- 2.9.8 BREAKPOINT 64-72
- 2.9.9 BREAKPOINT 73-81
- 2.9.10 BREAKPOINT 82-90
- 2.9.11 BREAKPOINT 91-99
- 2.9.12 BREAKPOINT 100-108
- 2.9.13 BREAKPOINT 109-117
- 2.9.14 BREAKPOINT 118-120

#### 2.10 MEASURED VALUES

- 2.10.1 MAIN OUTPUT
- 2.10.2 O/P NO LINEAR
- 2.10.3 O/P NO OFFSETS

#### 3. DIAGNOSTICS

- 3.1 FAULT RESET
- 3.2 ECHO PROFILE
- 3.3 TREND
- 3.4 PEAK VALUES
  - 3.4.1 MIN MEAS. VALUE
  - 3.4.2 MAX. MEAS. VALUE
  - 3.4.3 MINIMUM PV
  - 3.4.4 MAXIMUM PV
  - 3.4.5 MINIMUM SV
  - 3.4.6 MAXIMUM SV
- 3.5 ELECT TEMP
  - 3.5.1 MIN. VALUE
  - 3.5.2 MAX. VALUE
  - 3.5.3 INTERN. TEMP

## Menu structure

---

- 3.6 REMAIN. DEV. LIFE
  - 3.6.1 TIME IN OPER
  - 3.6.2 REMAIN LIFETIME
  - 3.6.3 REMIND. 1 (REQ.)
  - 3.6.4 REMIND. 2 (DEM.)
  - 3.6.5 REMINDER ACTIVATION
  - 3.6.6 LIFETIME EXPECTED
  - 3.6.7 MAINT STAT
  - 3.6.8 ACK STATUS
  - 3.6.9 ACK

- 3.7 REMAIN. SENS LIFE
  - 3.7.1 TIME IN OPER
  - 3.7.2 REMAIN LIFETIME
  - 3.7.3 REMIND. 1 (REQ.)
  - 3.7.4 REMIND. 2 (DEM.)
  - 3.7.5 REMINDER ACTIVATION
  - 3.7.6 LIFETIME EXPECTED
  - 3.7.7 MAINT STAT
  - 3.7.8 ACK STATUS
  - 3.7.9 ACK

## 4. SERVICE

- 4.1 DEMO MODE
- 4.2 MASTER RESET
- 4.3 POWERED HOURS
- 4.4 POWERON RESETS
- 4.5 LCD BACKLIGHT
- 4.6 LCD CONTRAST
- 4.7 SERVICE SCHEDULE
  - 4.7.1 TIME LAST SERV
  - 4.7.2 TIME NEXT SERV
  - 4.7.3 REMINDER 1 (REQ)
  - 4.7.4 REMINDER 2 (DEM)
  - 4.7.5 REMINDER ACTIVATION
  - 4.7.6 SERVICE INTERVAL
  - 4.7.7 MAINT STAT
  - 4.7.8 ACK STATUS
  - 4.7.9 ACK
- 4.8 CALIB. SCHEDULE
  - 4.8.1 TIME LAST CALIB
  - 4.8.2 TIME NEXT CALIB
  - 4.8.3 REMINDER 1 (REQ)
  - 4.8.4 REMINDER 2 (DEM)
  - 4.8.5 REMINDER ACTIVATION
  - 4.8.6 CALIB INTERVAL
  - 4.8.7 MAINT STATUS
  - 4.8.8 ACK STATUS
  - 4.8.9 ACK

## 5. COMMUNICATION

- 5.1 DEVICE ADDRESS
- 5.2 REMOTE LOCKOUT

## 6. SECURITY

- 6.1 WRITE PROTECTION

## 7. LANGUAGE



## Maintenance

---

### General items

- Opening the lid (cover)**  Before opening the lid for maintenance reasons observe following items:
- No dust deposits or whirlings are present.
  - No rain can enter into the housing

- Frequent check of the unit**  To ensure durable safety in hazardous locations and with electrical safety, following items must be checked frequently depending on the application:
- Mechanical damage or corrosion of any components (housing side and sensor side) and of the field wiring cables.
  - Tight sealing of the process connection, cable glands and enclosure lid.
  - Properly connected external PE cable (if present).

- Cleaning**
- The unit requires no cleaning under normal operating conditions.  
Under severe operating conditions, the antenna may require periodic cleaning.  
If cleaning is required by the application, following must be observed:
-  • Cleaning agent must comply with the materials of the unit (chemical resistance). Mainly the lid, antenna material, sealing, cable gland and the surface of the unit must be considered.
-  The cleaning process must be done in a way, that:
- The cleaning agent cannot enter into the unit through the lid sealing or cable gland.
  - No mechanical damage of the lid sealing, cable gland or other parts can happen.
  - Remove the instrument from service and wipe the antenna clean using a cloth and suitable cleaning solution.
- A possible accumulation of dust on the unit does not increase the maximum surface temperature and must therefore not be removed for purposes of maintaining the surface temperature in hazardous locations.

- Production date** The production date can be traced by the serial number on the typeplate. Please contact the manufacturer or your local distributor.

- Spare parts** All available spare parts are stated in the selection list

## Notes for use in Hazardous Locations

### Zone classification

	Category	Useable in zone	Equipment Protection Level (EPL)
Dust applications	1 D	20, 21, 22	Da
	2 D	21, 22	Db
	3 D *	22	Dc
Gas applications	3 G	2	Gc

\* In case of conductive dust, additional requirements for installation are necessary.

### ! Permitted zones (categories) for mounting in partition wall

EPL	Db	Gc
Category	2D	3G
Zone	21	2

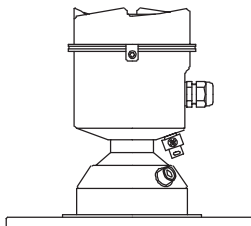
EPL	Da	Gc
Category	1D	3G
Zone	20	2

### ! General notes

#### Marking/ assembly

Devices with Ex-approval are marked on the type plate. For use and assembly and details of marking/coding, refer to the main part of this Instruction manual.

POTENTIAL ELECTROSTATIC CHARGING HAZARD DO NOT CLEAN WITH DRY CLOTH  DO NOT INSTALL WHERE BUILD-UP OF CHARGE IS LIKELY  USE SUITABLY RATED CABLE  DE-ENERGIZE BEFORE REMOVING COVER	 Sira 15ATEX4353X Ex nA II T4 Gc Un = 32 V  Ex nL IIC T4 Gc U <sub>i</sub> = 32 V I <sub>i</sub> = 22.63 mA C <sub>i</sub> ≤ 5 nF L <sub>i</sub> ≤ 20 µH	 Ex ta IIIC T139 °C Da SIRA 15ATEX9352X  IECEx SIR 150128X Ex ta IIIC T139 °C Da	 UWT GmbH www.uwt.de  NivoRadar NR 3000 NR 3100 xxxxxxx SERIAL NO.: GYZ / A1034567 ENCLOSURE: NEMA / TYPE 4X, 6; IP68 AMB. TEMP.: -40°C to 80°C INPUT: 24 V  NOM, 30 V  MAX., 4 - 20 mA HART	 CLASS II, DIV. 1, GR. E, F, G CLASS III, T4 CLASS I, DIV 2 GR. A, B, C, D TEMP CODE: T4 REFER TO INSTALLATION DWG. A5E36968501	 IC: 20874-NR3000 FCC ID: 2AF8D-NR3000 THIS DEVICE COMPLIES WITH PART 15 OF THE FCC RULES. OPERATION IS SUBJECT TO THE FOLLOWING TWO CONDITIONS: 1) THIS DEVICE MAY NOT CAUSE HARMFUL INTERFERENCE AND 2) THIS DEVICE MUST ACCEPT ANY INTERFERENCE RECEIVED INCLUDING INTERFERENCE THAT MAY CAUSE UNDESIRE OPERATION
		 UWT LEVEL CONTROL, BETZIGAU, GERMANY Assembled in Canada with domestic and imported parts			



2Ex nA IIC T4 Gc X  
 Ex ta IIIC T139°C Da X  
 TC RU C-DE.BH02.B.00473/20



См. Руководство по эксплуатации

#### Process pressure

Devices with Ex Approval are approved for atmospheric pressure.

A detailed explanation is given below for ATEX and applies analogously for other Ex approvals: The scope of the ATEX directive is generally limited to atmospheric pressure, see ATEX directive 2014\_34\_EU Chapter 1 Art.2 (4).

Atmospheric pressure is defined as absolute pressure 0.8bar to 1.1bar, see ATEX guideline §50 and IEC 60079-0 chapter 1 Scope.

The technical background is that an explosive atmosphere which is compressed (overpressure) or released (underpressure) can exhibit different explosion behaviour than under atmospheric conditions. The standards for the types of protection against explosion (IEC 60079 series), on which a type approval according to the ATEX directive is based, are designed for atmospheric conditions and do not automatically cover deviating pressure conditions.

Thus, an ATEX type approval issued in accordance with this directive only covers atmospheric pressure. This applies to all manufacturers.

A deviating operating pressure can be assessed and approved by an expert for the respective application. Regardless of this, the design of the level indicators is suitable for a vessel overpressure / underpressure in accordance with the specified technical data.

#### Process and ambient temperature

The equipment is certified for use in an ambient temperature range of -40°C to 80°C. The permitted temperature range is as well marked on the type plate.

#### Safety related device

The equipment has not been assessed as a safety related device (as referred to by Directive 2014/34/EU Annex II, clause 1.5).

#### Repair

Repair of this equipment shall be carried out by suitably trained and authorized personnel in accordance with the applicable code of practice.

## Notes for use in Hazardous Locations

### ! Maximum Surface Temperature

The maximum surface temperature refer to the warmest area outside on the unit which can occur in failure case (according to Ex definition).

Refer to the applicable code of practice for selection of this equipment with respect to specific dust ignition temperatures.

Max. Ambient temperature	Max. Surface temperature
80°C (176°F)	139°C (282°F)

### ! Installation Drawing Class I Div.2

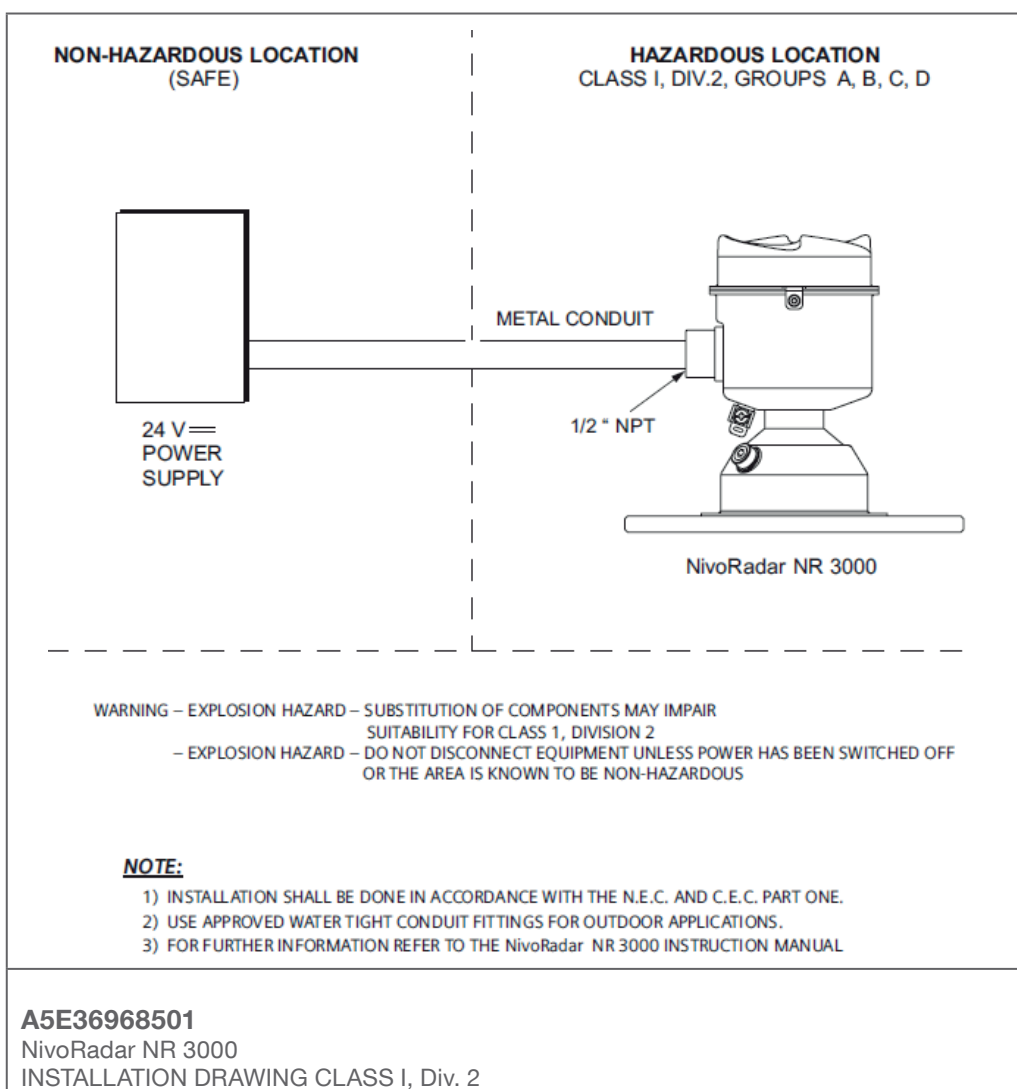



## Disposal

---

The product consists of materials which can be recycled, details of the used materials see chapter "Technical data - mechanical data".

Recycling must be done by a specialised recycling company.