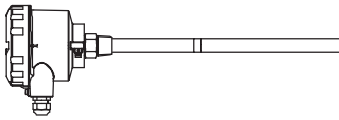
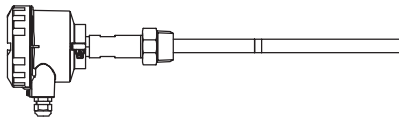

Table of contents

	Page
Safety Notes / Technical support	2
<hr/>	
Introducion	
Applications / Function / Features	3
Profibus System Implementation	4
<hr/>	
Technical data	
RF 8100	
	
RF 8200	
	
Dimensions	5
Electrical data	9
Mechanical data	11
Operating conditions	12
Approvals	16
<hr/>	
Mounting	17
<hr/>	
Electrical installation	20
<hr/>	
Operation - Electronic module: Standard	24
<hr/>	
Operation - Electronic module: Digital	30
<hr/>	
Notes for use in Hazardous Locations	31
<hr/>	
Probe Modifications	36
<hr/>	
Disposal	37

Subject to technical change.
 All dimensions in mm (inch).

We assume no liability for typing errors.
 Different variations than specified are possible.
 Please contact our technical consultants.

Safety notes / Technical support

Notes

- Installation, maintenance and commissioning may be accomplished only by qualified technical personnel.
- The product must be used only in the manner outlined in this instruction manual.
- This product is intended for use in industrial areas. Operation of this equipment in a residential area may cause interference to several frequency based communications.

Special attention must be paid to warnings and notes as follows:

WARNING



Relates to a caution symbol on the product: A failure to observe the necessary precautions can result in death, serious injury and/or considerable material damage.

WARNING



Relates to a caution symbol on the product: Risk of electric shock

WARNING





A failure to observe the necessary precautions can result in death, serious injury and/or considerable material damage.

This symbol is used, when there is no corresponding caution symbol on the product.

CAUTION

A failure to observe the necessary precautions can result in considerable material damage.

Safety symbols

In manual and on product	Description
	CAUTION: refer to accompanying documents (manual) for details.
	Earth (ground) Terminal
	Protective Conductor Terminal

Technical support

Please contact your local supplier (for address see www.uwt.de). Otherwise you can contact:

UWT GmbH
 Westendstr. 5
 D-87488 Betzigau

Tel.: 0049 (0)831 57123-0
 Fax: 0049 (0)831 76879
 info@uwt.de
 www.uwt.de

Introduction

Applications

RF 8000 is designed for level detection and simple pump control in a variety of applications:

- Liquids, solids (powder and granules), slurries, interface detection (for example, oil/ water), and foam detection
- Foods and pharmaceuticals
- Chemical and petrochemical
- High pressure and temperature

Function

RF 8000 is a versatile capacitance switch, ideal for level detection of interfaces, solids, liquids, slurries, and foam, and for simple pump control.

The switch responds to the presence of any material with a relative dielectric constant of 1.5 or more by detecting a change in capacitance, which is registered as a change in oscillating frequency.

The switch can be set to detect before contact or on contact with the probe. The RF 8000 requires a connection to earth/ground for effective capacitance measurement.

The power supply is galvanically isolated.

The materials used in the probe construction provide a high level of chemical resistance, and an excellent temperature rating on the process wetted portion of the probe: up to 400 °C (752 °F).

RF 8000 is available in two models: the standard model, and the digital model with integral local display.

Features

- Potted construction protects components from shock, vibration, humidity, and/or condensation
- High chemical resistance on probes
- Freely programmable set up covers wide range of applications/materials
- Integrated Local User Interface (LUI) for ease of use
- Rod and rope versions available
- Active Shield minimizes the effect of product build-up at the sensor mounting point
- Communication via PROFIBUS PA (profile version 3.0, Class B)
- Intrinsically Safe (IS) transmitter design for hazardous areas (requires external barrier or IS power supply)

Introduction

Profibus PA - System Implementation

RF 8000 supports PROFIBUS communication protocol, and SIMATIC PDM software.

Basic PLC configuration with PROFIBUS PA

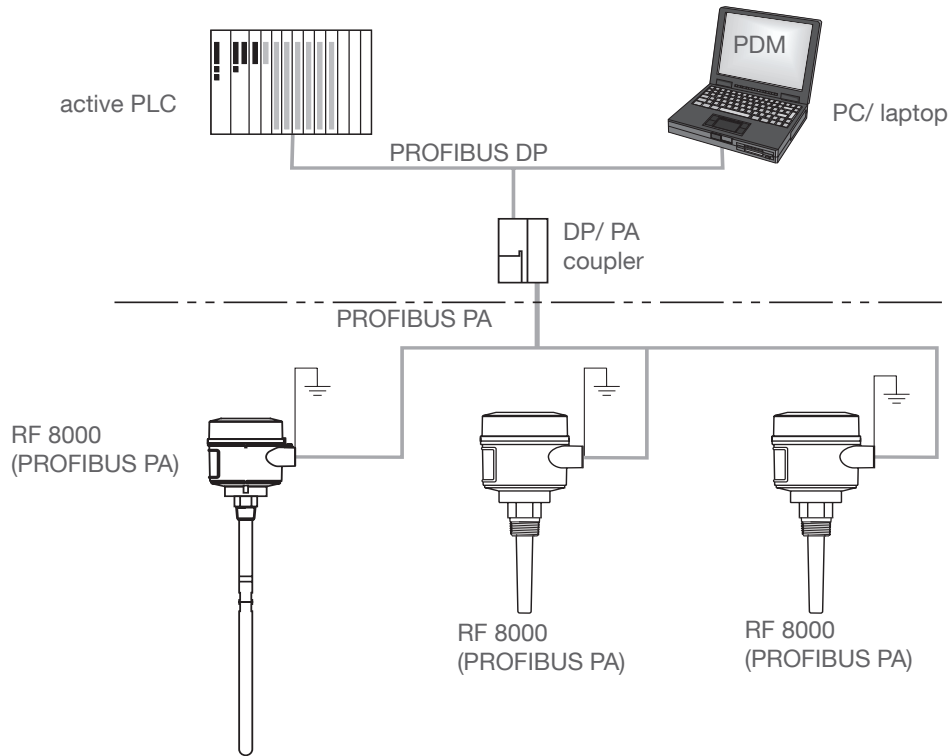

Programming

RF 8000 carries out its level measurement function according to the set of built-in parameters. You can make parameter changes locally via the local user interface, or from a remote location via a PC using SIMATIC PDM software.

RF 8000 Digital can be used either:

- as a standalone unit, programmed locally using the local user interface, or
- installed as part of a network, programmed remotely using SIMATIC PDM on Profibus PA network (or locally using the Local User Interface).

Alarm signalling

The solid-state switch can be set to react either to a diagnosed fault in the instrument, or to a change in the process level.

Fault Signalling

RF 8000 can actively report information on its own status via PROFIBUS PA when used as part of a network, or by means of a pre-defined output status at the solid state switch and on the Local User Interface (LUI).

Technical data - Dimensions

Enclosure

RF 8100
 RF 8200
 Top view

M20x1.5 cable gland

NPT 1/2" conduit

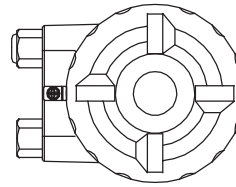
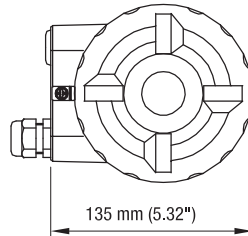

RF 8100
 RF 8200
 Threaded
 process connection

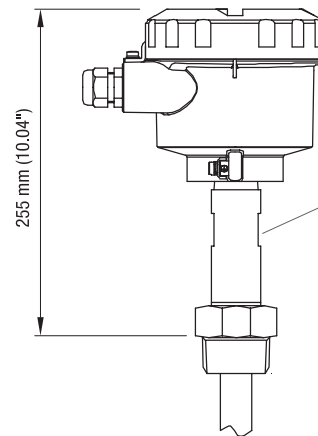
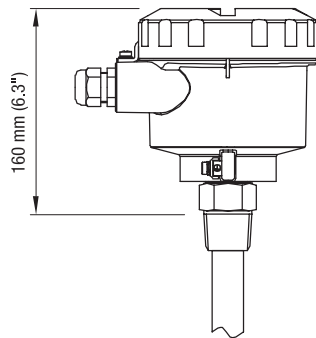

Temperatur extended shaft:
 RF 8100 optional
 RF 8200 standard

RF 8100
 RF 8200
 Flanged
 process connection

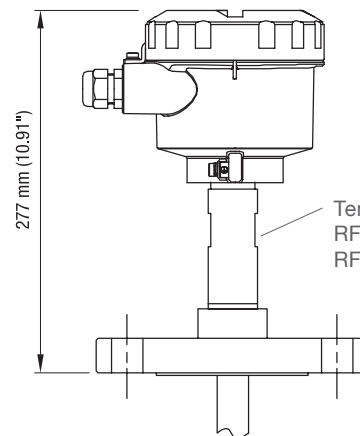
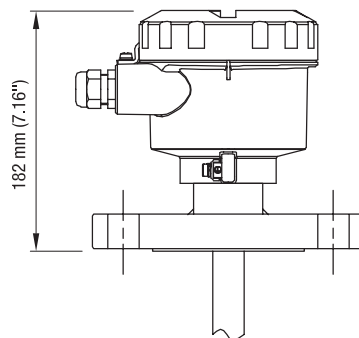

Temperatur extended shaft:
 RF 8100 optional
 RF 8200 standard

Technical data - Dimensions

RF 8100 Rod version
 RF 8200 Rod version (high temperature)

Threaded process connection

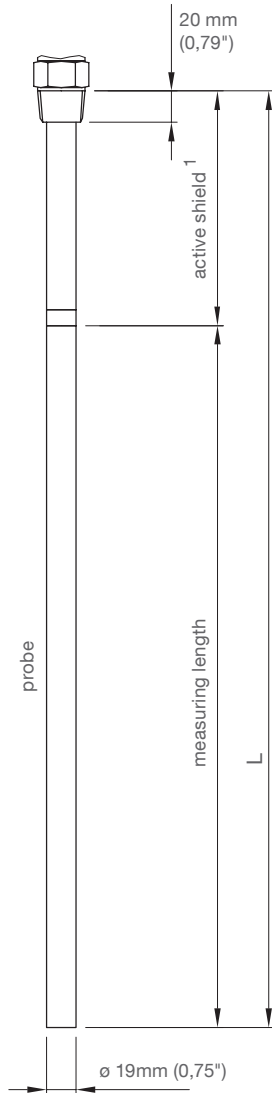

Flanged process connection

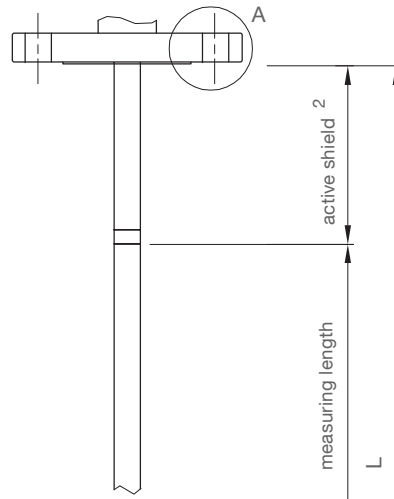

Detail "A"

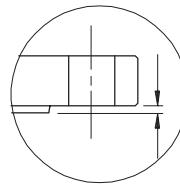

L does not include any raised face (see page 8)

¹ For RF8100 coated with PFA
 Standard 125mm (4.92")
 Optional 250 mm (9.84") or
 400 mm (15.75")

² For RF8100 coated with PFA
 Standard 105 mm (4.13")
 Optional 230 mm (9.06") or
 380 mm (14.96")

Technical data - Dimensions

RF 8100 Rope version

Threaded process connection

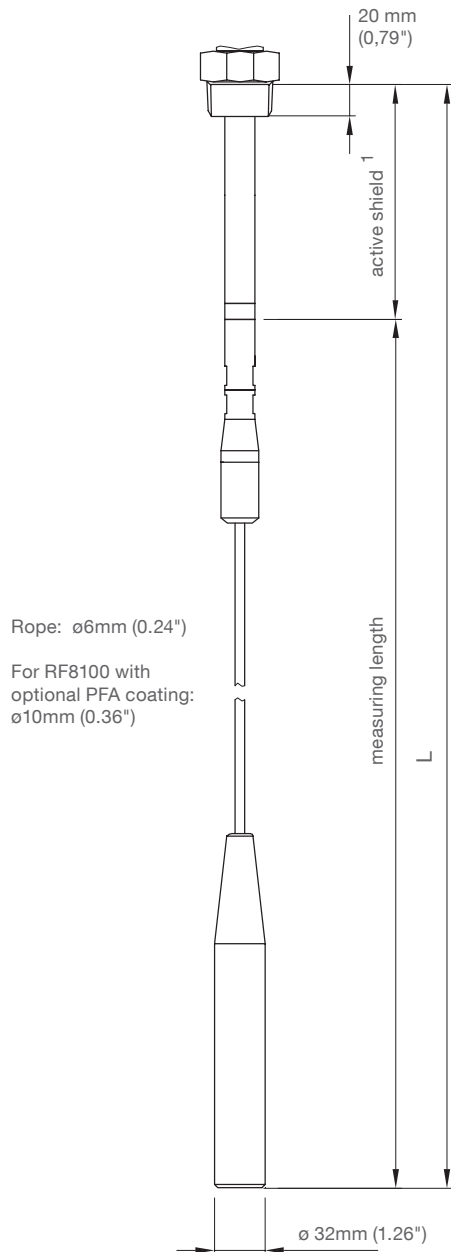

Flanged process connection

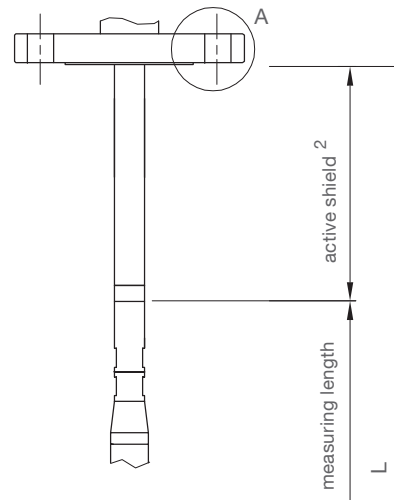

Detail "A"

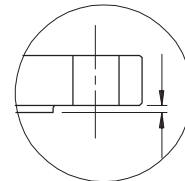

L does not include any raised face (see page 8)

¹ Coated with PFA
 Standard 125mm (4.92")
 Optional 250 mm (9.84") or
 400 mm (15.75")

² Coated with PFA
 Standard 105 mm (4.13")
 Optional 230 mm (9.06") or
 380 mm (14.96")

Technical data - Dimensions

Flanges

	Code	Type	Number of holes	d2 mm (inch)	Lk mm (inch)	D mm (inch)	T thickness mm (inch)
ASME B16.5, raised face	5A	1" 150 lbs	4	15.9 (0.63)	79.3 (3.12)	108.0 (4.25)	14.3 (0.56)
	5B	1" 300 lbs	4	19.1 (0.75)	88.9 (3.5)	123.8 (4.87)	17.5 (0.69)
	5C	1" 600 lbs	4	19.1 (0.75)	88.9 (3.5)	123.8 (4.87)	17.5 (0.69)
	5D	1½" 150 lbs	4	15.9 (0.63)	98.6 (3.88)	127.0 (5.0)	17.5 (0.69)
	5E	1½" 300 lbs	4	22.2 (0.87)	114.3 (4.5)	155.6 (6.13)	20.6 (0.81)
	5F	1½" 600 lbs	4	22.2 (0.87)	114.3 (4.5)	155.6 (6.13)	22.4 (0.88)
	5G	2" 150 lbs	4	19.1 (0.75)	120.7 (4.75)	152.4 (6.01)	19.1 (0.75)
	5H	2" 300 lbs	8	19.1 (0.75)	127.0 (5.0)	165.1 (6.5)	22.2 (0.87)
	5J	2" 600 lbs	8	19.1 (0.75)	127.0 (5.0)	165.1 (6.5)	25.4 (1.0)
	5K	3" 150 lbs	4	19.1 (0.75)	152.4 (6.01)	190.5 (7.5)	23.9 (0.94)
	5L	3" 300 lbs	8	22.2 (0.87)	168.2 (6.62)	209.6 (8.25)	28.6 (1.13)
	5M	3" 600 lbs	8	22.2 (0.87)	168.2 (6.62)	209.6 (8.25)	31.7 (1.25)
	5N	4" 150 lbs	8	19.1 (0.75)	190.5 (7.5)	228.6 (9.0)	23.9 (0.94)
5P	4" 300 lbs	8	22.2 (0.87)	200.0 (7.87)	254.0 (10.0)	31.7 (1.25)	
5Q	4" 600 lbs	8	25.4 (1.0)	215.9 (8.5)	273.1 (10.75)	38.1 (1.5)	
EN 1092-1 type A, flat faced	6A	DN25 PN16	4	14.0 (0.55)	85.0 (3.35)	115.0 (4.53)	18.0 (0.71)
	6B	DN25 PN40	4	14.0 (0.55)	85.0 (3.35)	115.0 (4.53)	18.0 (0.71)
	6C	DN40 PN16	4	18.0 (0.71)	110.0 (4.33)	150.0 (5.91)	18.0 (0.71)
	6D	DN40 PN40	4	18.0 (0.71)	110.0 (4.33)	150.0 (5.91)	18.0 (0.71)
	6E	DN50 PN16	4	18.0 (0.71)	125.0 (4.92)	165.0 (6.5)	18.0 (0.71)
	6F	DN50 PN40	4	18.0 (0.71)	125.0 (4.92)	165.0 (6.5)	20.0 (0.79)
	6G	DN80 PN16	8	18.0 (0.71)	160.0 (6.3)	200.0 (7.87)	20.0 (0.79)
	6H	DN80 PN40	8	18.0 (0.71)	160.0 (6.3)	200.0 (7.87)	24.0 (0.94)
	6J	DN100 PN16	8	18.0 (0.71)	180.0 (7.09)	220.0 (8.66)	20.0 (0.79)
	6K	DN100 PN40	8	22.0 (0.87)	190.0 (7.48)	235.0 (9.25)	24.0 (0.94)

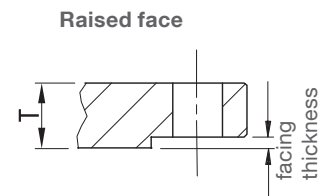
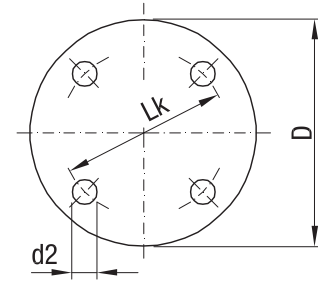

Type	Facing thickness
ASME 150 lb	2 mm (0.08")
ASME 300 lb	
ASME 600 lb	7 mm (0.28")

Technical data - Electrical data

Electronic module: Standard (Relay SPDT / Solid State)

Power

Supply	12 to 250 V AC/DC (0 to 60 Hz)
Ex approvals	Max. voltage which does not invalidate the intrinsically safe protection of the sensor (probe): Um = 250V AC
Power consumption	2 W max.

Performance

Repeatability	±1% of measurement
---------------	--------------------

User Interface

Configuration	Locally, using dip switches and potentiometers
Local display	3 LED indicators
Output	Relay contact and solid-state switch
Polarity-independent	Yes
Failsafe	Relay and solid-state switch can be de-energized in the absence of a sensor signal

Signal Outputs

Relay	1 Form C (SPDT) contact (selectable NC or NO contact) max. switching voltage/ current (DC): 30 V DC/ 5 A max. switching voltage/ current (AC): 250 V AC/ 8 A (resistive load)
Solid-state switch	Rated 30 V DC or peak 30 V AC, 82 mA
Time delay	Selectable, Probe covered to uncovered 1 to 42 seconds / Probe uncovered to covered 1 to 100 seconds
Hysteresis	Dependent on DK: max. 2 mm (0.08") @ DK = 1.5
Failsafe operation	Failsafe High or Failsafe Low

Electronic module: Digital (Profibus PA/ Solid State)

Power

Bus voltage	
- General purpose	12 to 30 V DC, 12.5 mA
- Intrinsically Safe	12 to 24 V DC, 12.5 mA, FISCO Field Device Intrinsically safe barrier required $U_i = 24\text{ V}$ $I_i = 380\text{ mA}$ $P_i = 5.32\text{ W}$ $C_i = 5\text{ nF}$ $L_i = 10\text{ uH}$ for FM/ CSA: see page 23
Ex approvals	Max. voltage which does not invalidate the intrinsically safe protection of the sensor (probe): Um = 250V AC
Starting current < current of normal operation	Yes
Fault current	0 mA
Fault disconnect equipment (FDE)	Yes
Auxiliary source	Bus powered
Separate supply necessary	No

Performance

Repeatability	Approx. ± 2 mm for a conductive fluid
---------------	---------------------------------------

Technical data - Electrical data

User Interface

Configuration

Locally, using local user interface (LUI), for standalone operation, or
 Remotely, using SIMATIC PDM on a Profibus PA network

Local Digital Display	LCD
Output (bus)	PROFIBUS PA (IEC 61158 CPF3 CP3/2) Bus physical layer: IEC 61158-2 MBP(-IS)
Polarity-independent	yes
Simultaneous communication with Master Class 2	4 (max.)
Cyclic User data (normal operation)	
Byte output	2 bytes representing one value
Byte input	0
Device profile	PROFIBUS PA Profile for Process Control Devices Version 3.0, Class B
Function blocks	1
Discrete input	1
Logical inversion	Parameterizable
Simulation functions	
Output	yes
Input	yes
Failsafe	Parameterizable (last usable value, substitute value, erroneous value)
Block Structure	
Physical block	1
Transducer block	1
Transducer block discrete input	Yes
Monitoring measuring limits	Yes
Alarm Output	
Solid-state switch	Galvanically isolated, non-polarity sensitive transistor Rated 30V DC or peak AC max., 82mA max Voltage drop below 1 V typical @ 50 mA With Intrinsically safe: barrier required $U_i = 30\text{ V}$ $I_i = 200\text{ mA}$ $P_i = 350\text{ mW}$ $C_i = 0$ $L_i = 0$ for FM/ CSA: see page 23
Time delay	Selectable, Probe covered to uncovered, Probe uncovered to covered
Hysteresis	100% adjustable
Failsafe operation	Failsafe High or Failsafe Low
Terminal	Removable terminal block, 2.5 mm ² max.

Diagnostics

Input Reed contact: for test function

Technical data - Mechanical data

Probe

Model	Length (max)	Process Connections	Tensile (max)	Wetted Parts
Rod (19 mm/ 0.75" dia.)	1,000 mm/ 40"	<ul style="list-style-type: none"> Threaded: ¾" 1" 1 ½" BSPT (R), BSPP (G) ¾" 1" 1 ¼" 1 ½" NPT Welded flange: ASME: 1" 1 ½" 2" 3" 4" DN 25 40 50 80 100 	n/a	<ul style="list-style-type: none"> 1.4404 (316L) FKM seals (optional FFKM) PFA lining on Active Shield PEEK isolators
Rope	25,000 mm/ 985"	<ul style="list-style-type: none"> Threaded: ¾" 1" 1 ½" BSPT (R), BSPP (G) ¾" 1" 1 ¼" 1 ½" NPT Welded flange: ASME: 1" 1 ½" 2" 3" 4" DN 25 40 50 80 100 	1,900 kg/ 4,188 lbs	<ul style="list-style-type: none"> 1.4404 (316L) Active Shield and cable weight 1.4404 (316L) cable (optional PFA jacketed cable) FKM seals (optional FFKM) PEEK isolators
High Temperature version	1,000 mm/ 40"	<ul style="list-style-type: none"> Threaded: ¾" 1" 1 ½" BSPT (R), BSPP (G) ¾" 1" 1 ¼" 1 ½" NPT Welded flange: ASME: 1" 1 ½" 2" 3" 4" DN 25 40 50 80 100 	n/a	<ul style="list-style-type: none"> 1.4404 (316L) Ceramic isolators

Active Shield Length			Minimum length of extension "L"		
Active Shield	Threaded	Flanged	Rod version	Rope version	High Temp. version
Standard length	125 mm/4.92"	105 mm/4.13"	350 mm/13.78"	500 mm/19.69"	350 mm/13.78"
Extended shield	250 mm/9.84"	230 mm/9.06"	500 mm/19.69"	1000 mm/40"	500 mm/19.69"
Extended shield	400 mm/15.75"	380 mm/14.96"	750 mm/29.53"	1000 mm/40"	750 mm/29.53"

Enclosure

Termination	Removable terminal block, 2.5 mm ² max.
Construction	Powder-coated aluminum with gasket
Optional thermal isolator	1.4404 (316L) stainless steel
Cable entry	2 x M20 thread (option: 1 x ½" NPT thread with adaptor)
Ingress protection	Type 4 / IP65 or IP68 (depending on Cable Entry option) Note: The use of approved watertight conduit hubs/glands is required for Type 4 / IP65 or IP68 (outdoor applications).
Separation between Zone 0 and Zone 1 (EPL Ga/Gb)	Material of the separation element (partition wall) - Stainless steel, 1.4404 (316L) - Glass, Inconel 600 (Glass seal)

Weight

Weight varies based on configuration. For example:

- Compact, 100 mm (4") insertion length, ¾" process connection, 1 kg (2.20 lb.) approx.

Technical data - Operating conditions

Environmental

Location	Indoor/outdoor
Altitude	2,000 m (6,562 ft.) max.
Ambient temperature	-40 to 85°C (-40 to 185°F) With Ex approval: Depending on Surface Temperature and Temperature Class, details see page 35.
LUI (local user interface)	-30 to 85°C (-22 to 185°F)
Storage temperature	-40 to 85°C (-40 to 185°F)
Relative humidity	Suitable for outdoor
Installation category	II (Electronic module: Standard) I (Electronic module: Digital)
Pollution degree	4

Process

Relative dielectric constant	1.5 minimum
Temperature at process connection - Rod / rope version	Without temperature extended shaft: -40 to 85°C (-40 to 185°F) -20 to 85°C (-4 to +185°F) with option FFKM seal O-ring With temperature extended shaft: -40 to 200°C (-40 to 392°F) -20 to 200°C (-4 to +392°F) with option FFKM seal O-ring
- High temperature version	-40 to 400°C (-40 to 752°F) With Ex approval: Depending on Surface Temperature and Temperature Class, details see page 35.
Pressure (vessel)	-1 to 35 bar g/ -14.6 to 511 psi g (nominal) note: please see Pressure versus Temperature Curves on next pages.

Technical data - Operating conditions

Pressure versus Temperature Curves

Extended rod and rope versions, threaded

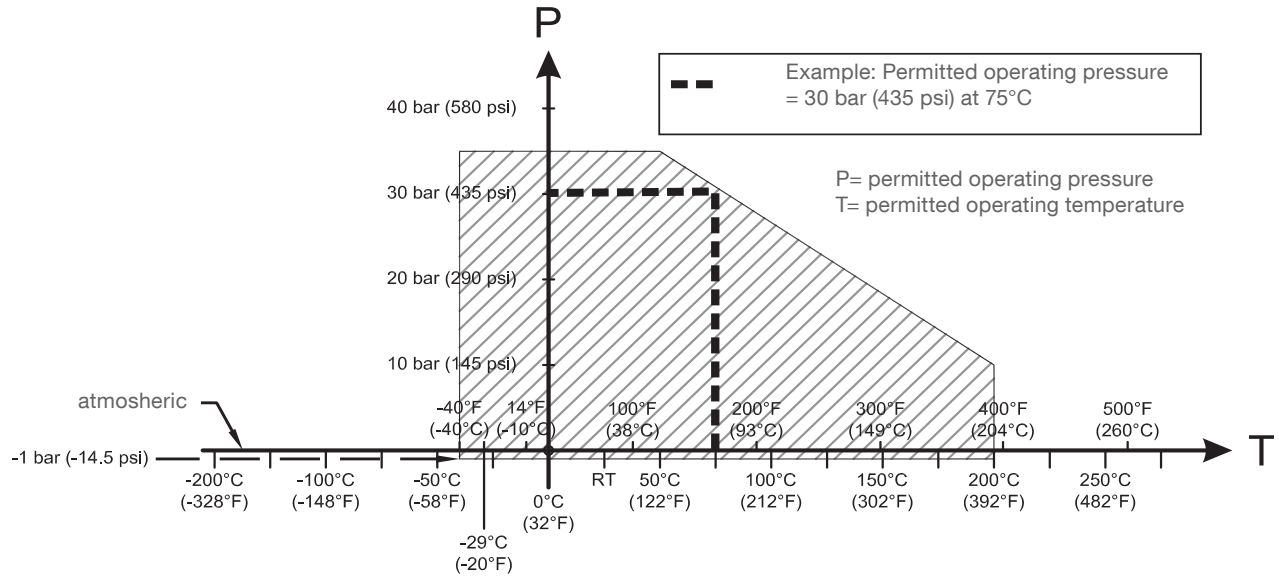

High temperature rod version, threaded

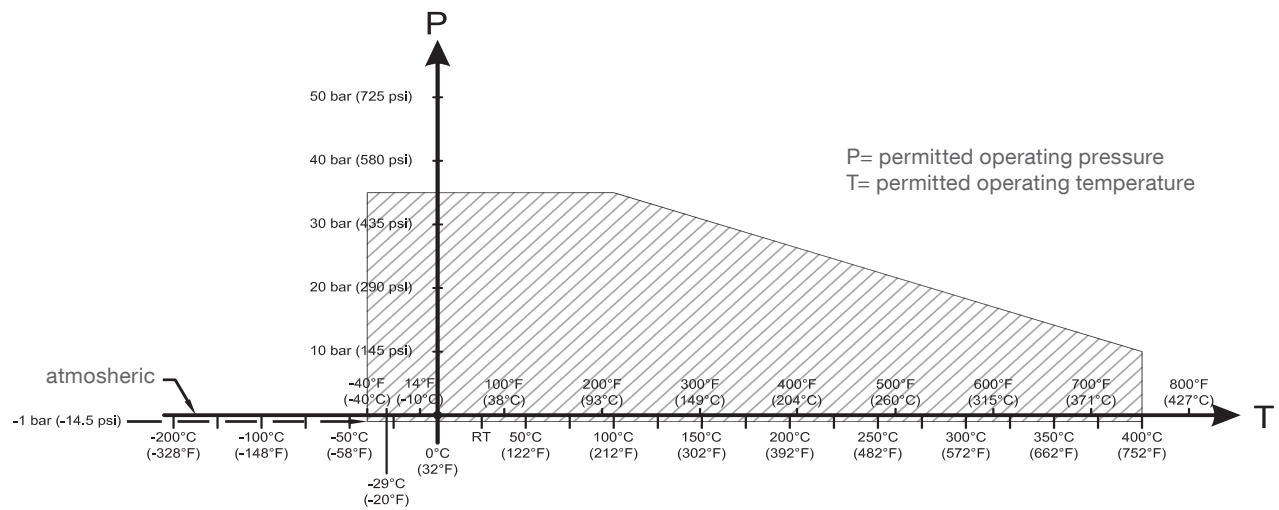

Technical data - Operating conditions

Extended rod and rope versions, ASME welded flange

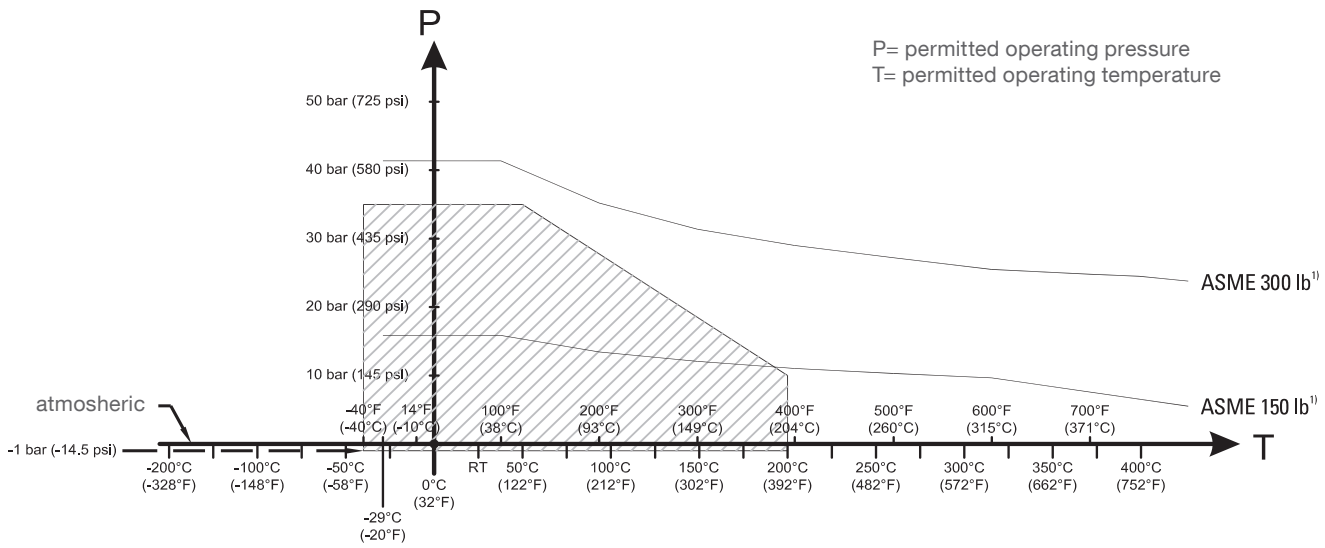

High temperature rod version, ASME welded flange

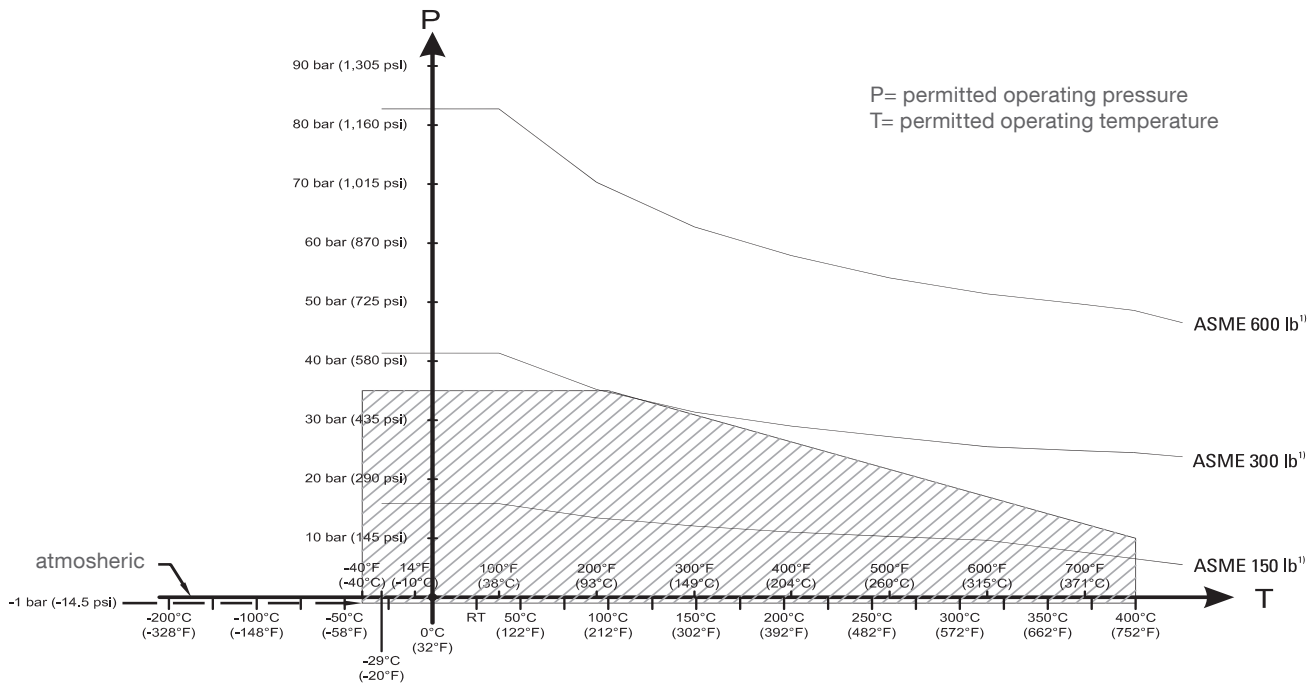

1) The curve denote the minimum allowable flange class for the shaded area below.

Technical data - Operating conditions

Extended rod and rope versions, EN welded flange

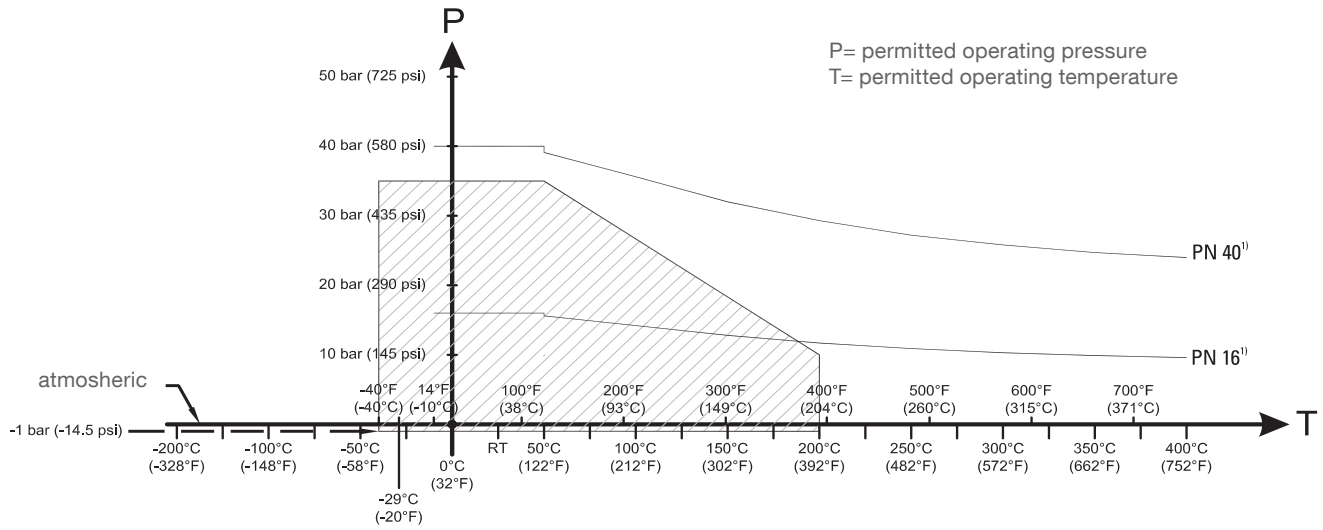

High temperature rod version, EN welded flange

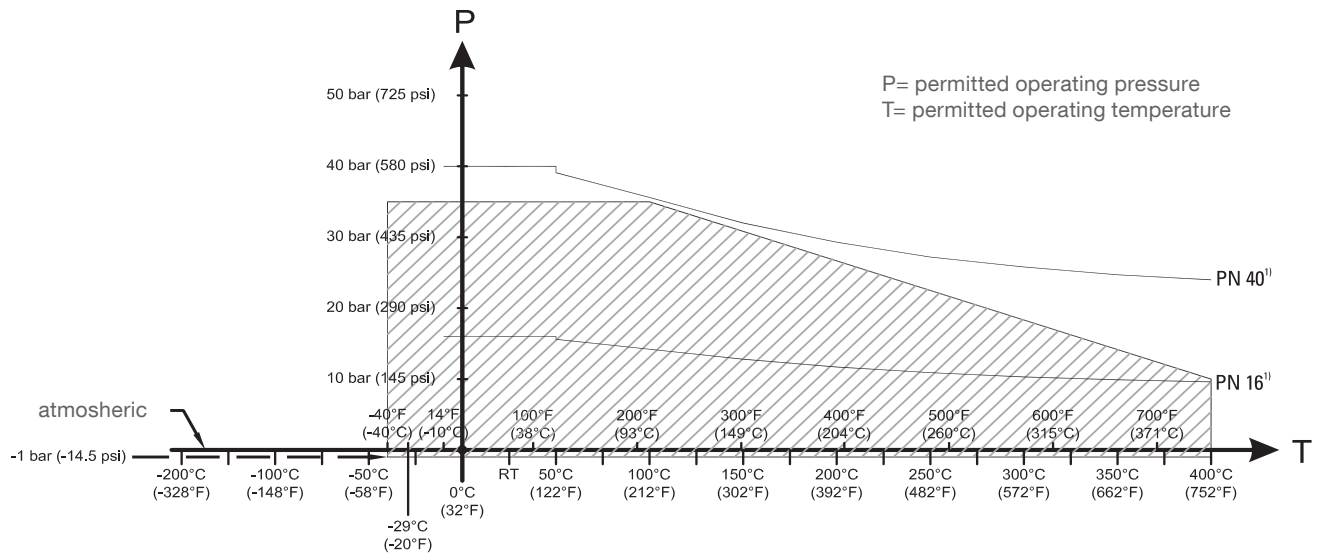

1) The curve denote the minimum allowable flange class for the shaded area below.

Approvals

Electronic module: Standard (Relay SPDT / Solid State)

General Purpose	CE, CSA, FM, TR-CU
Dust Ignition Proof	ATEX II 1/2D, IIIC CSA/FM Class II, Div. 1, Gr. E, F, G Class III TR-CU INMETRO
Flame Proof / Explosion Proof	ATEX II 1/2G, IIC CSA/FM Class I, Div. 1, Gr. A, B, C, D TR-CU INMETRO
Marine	Lloyds Register of Shipping, Categories ENV1, ENV2 and ENV5
Overfill Protection	WHG

Electronic module: Digital (Profibus PA / Solid State)

General Purpose	CE, CSA, FM, TR-CU
Dust Ignition Proof	ATEX II 1/2D, IIIC CSA/FM Class II, Div. 1, Gr. E, F, G Class III TR-CU INMETRO
Flame Proof / Explosion Proof	ATEX II 1/2G, IIC CSA/FM Class I, Div. 1, Gr. A, B, C, D TR-CU INMETRO
Intrinsically Safe ¹	ATEX II 1G, IIC CSA/FM Class I, Div. 1, Gr. A, B, C, D TR-CU INMETRO
Marine	Lloyds Register of Shipping, Categories ENV1, ENV2 and ENV5

¹ Barrier or Intrinsically Safe power supply required for Intrinsically Safe protection

Note: EN61326 (CE EMC) testing was conducted on the RF 8000 rod version while mounted in a metallic vessel and wired using shielded cable. Units with flange process connections were tested while mounted in a metallic vessel with a metallic gasket and with shielded cables.

Mounting



General Safety Instructions

- Installation shall only be performed by qualified personnel and in accordance with local governing regulations.
- This product is susceptible to electrostatic shock. Follow proper grounding procedures.
- The housing may only be opened for maintenance, local operation, or electrical installation.
- Before installing the instrument, verify that the environment complies with any restrictions specified on the product nameplate.
- To comply with CE EMC regulations, where applicable, the RF 8000 should be installed in accordance with the testing details on page 16.



Additional Safety Instructions for Hazardous Locations

see page 31ff

Location

Recommended:

- Provide a sun shield to protect the transmitter from direct heat radiation.

Precautions:

- Avoid mounting RF 8000 in locations subject to strong vibrations in the vicinity, whenever possible.
- Do not exceed the permissible ambient temperature limits (see Environmental on page 12 for details).

Mounting

RF 8000 typical configuration:

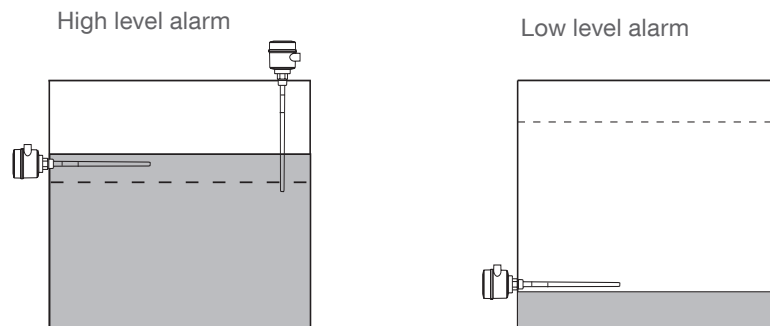

For high level alarm (level exceeds normal process level):

- normally mounted into the vessel top, or
- mounted through the tank wall at the detection level

For low level alarm (level drops below normal process level):

- mounted through the tank wall at the detection level

Angled mounting:

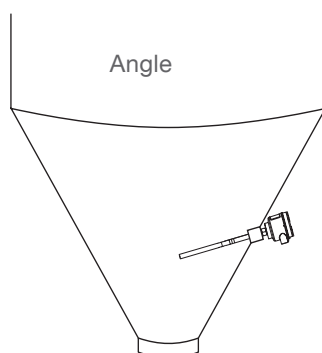

RF 8000 rope version:

The rope version is designed for top mounting. The cable suspends vertically so that it reaches into the process at the desired detection level (high or low detection alarm).

Mounting

Mounting Restrictions

- Keep the sensor at least 50 mm (2") away from any nozzle or tank wall.
- If multiple units are used, allow at least 500 mm (20") between them, to prevent interference.

Multiple Units:

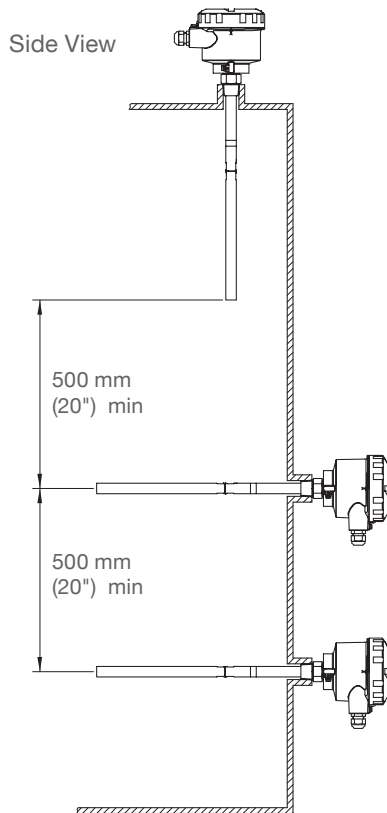

Sensors must be 500 mm (20") apart.

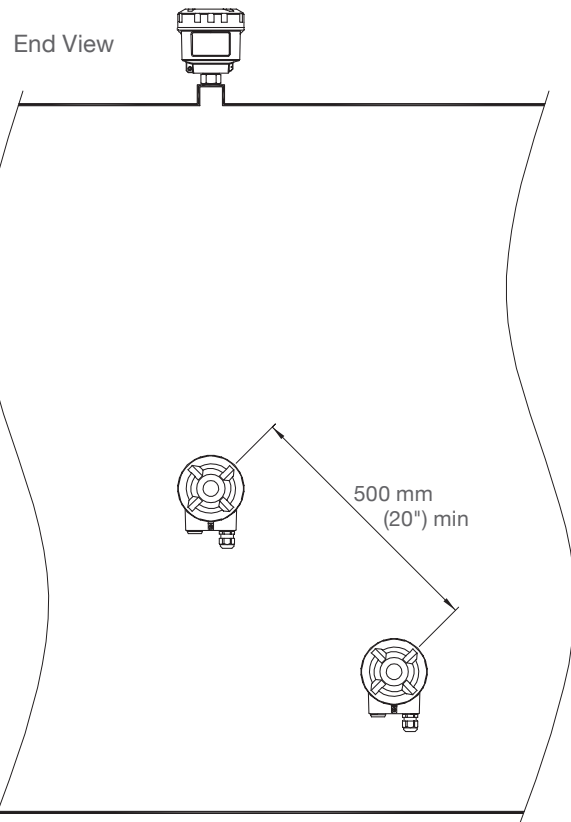

Mount diagonally if space is restricted.

Wall Restriction:

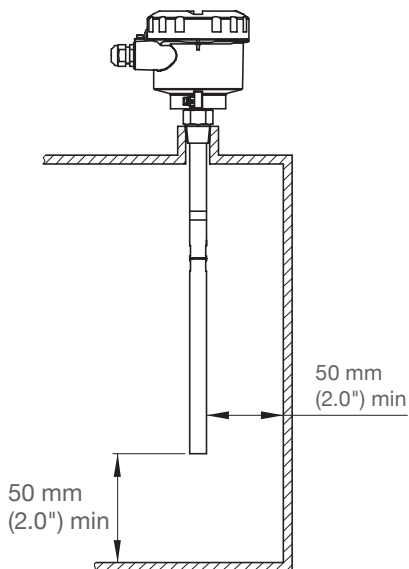

Mounting

Process Cautions for solids

- In Hazardous Locations: Observe Specific condition of use for electrostatic charge (see page 33)

- The maximum allowable torque on a horizontally installed rod is 15 Nm.
- Keep unit out of path of falling material, or protect probe from falling material.

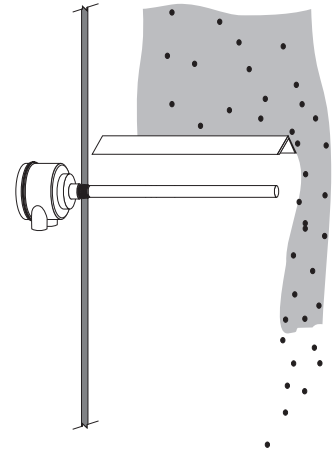
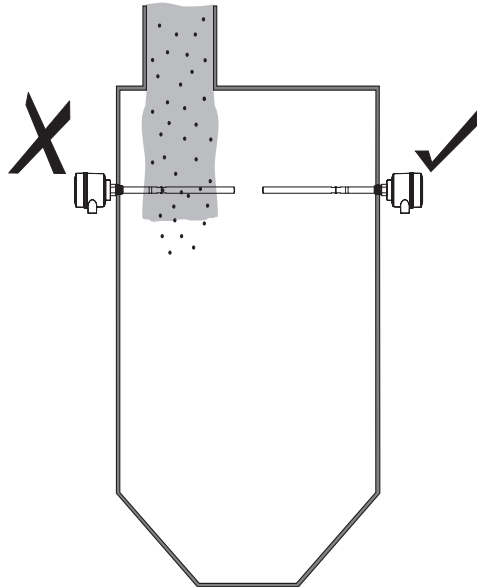

- Consider material surface configuration when installing unit.
- Tensile load must not exceed probe or vessel rating.

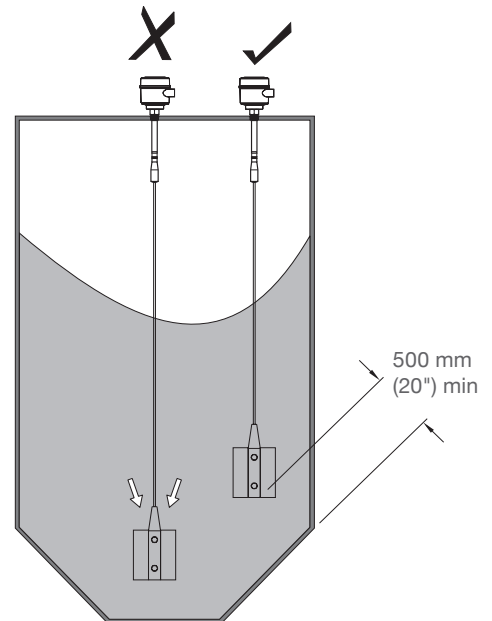
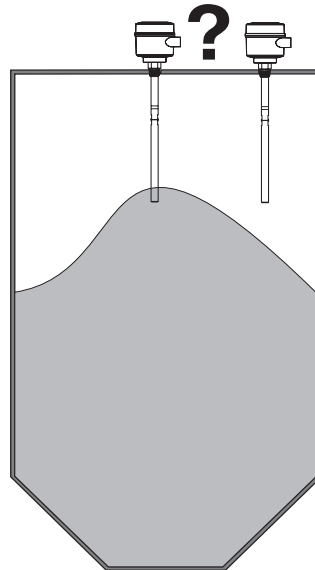

Note: Buildup of material in Active Shield area does not affect switch operation.

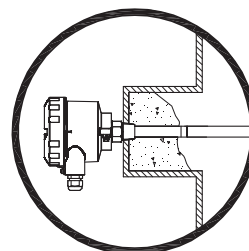
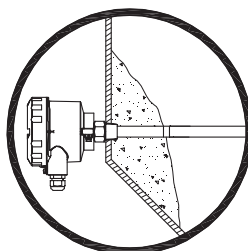

Electrical installation

! General Safety Instructions

Electronic module: Standard (Relay SPDT / Solid State)

WARNING:

- All field wiring must have insulation suitable for at least 250 V.
- Only qualified personnel are authorized to install and operate this equipment in accordance with established safety practices and standards.
- The Protective Earth Terminal indicated by  must be connected to reliable ground. In case of non-metallic vessels, the external earth wire should be connected to an earthed component which is earthed near the vessel.
- All wiring must be done by qualified personnel in accordance with all governing regulations.
- The equipment must be protected by a 15A fuse or circuit breaker in the building installation.
- A circuit breaker or switch in the building installation, marked as a disconnect switch, shall be in close proximity to the equipment and within easy reach of the operator.
- Use shielded cable, wire gauge 20 AWG to 14 AWG (0.5 mm² to 2.0 mm²). For CE installations use a cable with a braided metallic shield (or armoured cable where applicable).
- Maximum working voltage between adjacent relay contacts is 250 V.
- Relay contact terminals are for use with equipment which has no accessible live parts and wiring which has insulation suitable for at least 250 V.
- Cable entry devices and closing elements of unused apertures must meet a temperature range from min. -40°C to 10 K above max. ambient temperature.

Electronic module: Digital (Profibus PA / Solid State)

WARNING:

- Observe the specifications of the examination certificate valid in your country.
- Observe the laws and regulations valid in your country for electrical installations in potentially explosive atmospheres.
- Refer to Hazardous Area Installation on page 31 if applicable.
- Ensure that the available power supply complies with the power supply specified on the product nameplate and specified in the examination certificate valid in your country.
- Shipping plugs in the cable inlets must be replaced by suitable screwtype glands or dummy plugs, which are appropriately certified for transmitters with explosion-proof protection.
- For CE installations, use a cable with a braided metallic shield (or armoured cable where applicable).
- The lid must not be opened in wet locations while the unit is powered. (A wet location is a location where water or another conductive fluid may be present and is likely to increase the risk of electric shock.)
- Cable entry devices and closing elements of unused apertures must meet a temperature range from min. -40°C to 10 K above max. ambient temperature.

Notes:

- Lay PROFIBUS PA cable separately from power cable with voltages greater than 60 V.
- Avoid locating the unit near large electrical equipment wherever possible.
- Connect the cable shield to earth (for example, to the housing by means of a metallic screwed gland).

! Additional Safety Instructions for Hazardous Locations

• see page 31ff

Electrical installation

Electronic module: Standard (Relay SPDT / Solid State)

Power supply:

12 to 250 V AC/DC (0 to 60 Hz)
 2W max.

Signal output:

Relay:
 Floating relay SPDT
 AC max. 250V, 8A, 2000VA, non inductive
 DC max. 30V, 5A, 150W, non inductive

Solid state switch:
 30 V DC or 30 V AC (peak), 82 mA
 Observe protection (see below)

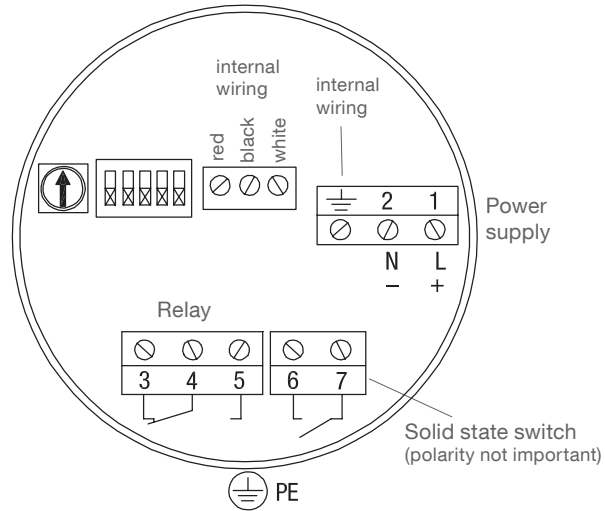

1. Loosen the lid clip and remove the lid to access the connectors and electronics.
2. Connect the wires to the terminals
3. Ground the instrument according to local regulations.
4. Tighten the gland to form a good seal.

Connect protective earth wire to terminal provided in housing and marked with

Use crimp type cable socket for 4 mm screw diameter, ring form or U-form (e. g. DIN 46234).

Protection of Solid State Switch

Observe a Protection diode in case of connecting an external relay to the Solid state switch

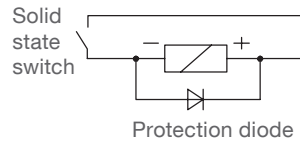

Note: Switch and potentiometer settings are for illustration purposes only.

Electrical installation

Electronic module: Digital (Profibus PA / Solid State)

Power supply:

12 .. 30 V DC, 12.5 mA

Intrinsically Safe:

12 .. 24 V DC, 12.5 mA

Intrinsically safe barrier required

$$U_i = 24 \text{ V}, I_i = 380 \text{ mA}, P_i = 5.32 \text{ W}, C_i = 5 \text{ nF}, L_i = 10 \text{ uH}$$

For FM/ CSA: See "Connection drawing on page 23"

Signal output:

Solid state switch:

30 V DC or 30 V AC (peak), 82 mA

Observe protection (see below)

Intrinsically safe:

Intrinsically safe barrier required

$$U_i = 30 \text{ V}, I_i = 200 \text{ mA}, P_i = 350 \text{ mW}, C_i = 0, L_i = 0$$

For FM/ CSA: See "Connection drawing on page 23"

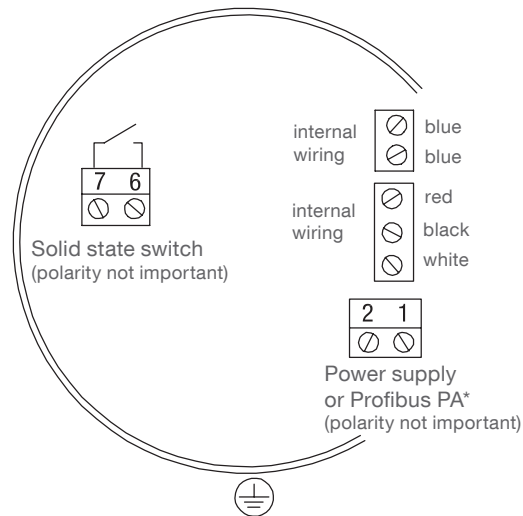

* With use of Profibus PA the wiring must be according to Profibus PA standards. If Profibus PA is not used, a shielded cable is recommended to ensure stable measurement.

Connect protective earth wire to terminal provided in housing and marked with

Use crimp type cable socket for 4 mm screw diameter, ring form or U-form (e. g. DIN 46234).

Protection of Solid State Switch:

Observe a Protection diode in case of connecting an external relay to the Solid state switch

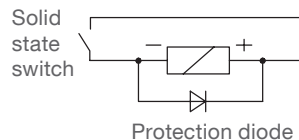

Connecting the electronic module:

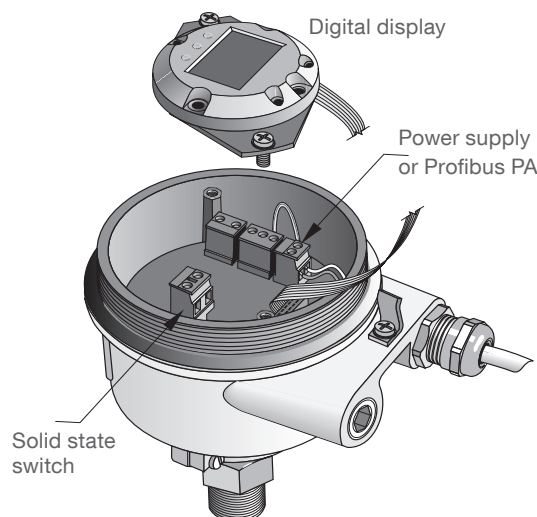

1. Loosen the lid clip and unscrew the lid of the enclosure.
2. Unscrew and lift up the digital display (loosen each screw two turns before completely loosening both, to keep the rubber retaining rings in place.)
3. Connect the wires to the terminals
4. Ground the instrument according to local regulations.
5. Tighten the cable gland to form a good seal.
6. Fix the digital display.
7. To adjust the transmitter locally, using the keypad, go to Programming via the Local User Interface (LUI).
After adjustment, replace the enclosure lid and tighten the lid clip.

Electrical installation

FM/CSA approval Connection drawing

Unclassified Location

Entity Parameter	GROUPS A, B, C, D, E, F, G, IIC		GROUPS C, D, E, F, G, IIB	
	Current Loop Output	Solid State Output	Current Loop Output	Solid State Output
Ui (Vmax)	24 V	30 V	24 V	30 V
Ii (imax)	380 mA	110 mA	380 mA	200 mA
Pi	5.32 W	825 mW	5.32 W	1.5 W
Ci	5 nF	0	5 nF	0
Li	10 µH	0	10 µH	0

NOTES:

- 1) Fieldbus input: specified to the fisco model
- 2) Manufacturer's installation instructions must be followed for installation of Associated Intrinsically Safe Apparatus
- 3) Either one or both wire pairs between Associated Intrinsically Safe Apparatus must be grounded screened or shielded wires.
- 4) For FM: Installation must be in accordance with ANSI / ISA 12.06.01 and the National Electrical Code (ANSI / NFPA 70)
- 5) For CSA: Installation must be in accordance with applicable section of Canadian Electrical Code (CEC)
- 6) For Division 2 installation, associated apparatus is not required, installation must be in accordance with Division 2 wiring methods and supply voltage must not exceed 30 Volts
- 7) Dust-tight seals must be used for Class II and III installations
- 8) The RF 8000 / CN 8000 transmitter is approved for Class I, Zone 0 applications if connecting to AEx[ia] rated Associated Intrinsically Safe Apparatus. The transmitter is suitable only for Class I, Zone 1 or Zone 2, and not suitable for Class 1, Zone 0 or Class, Division 1 applications
- 9) For FM the unit must be installed using FM Approved Apparatus

Hazardous (Classified) Location

IS CLASS I, II, III, DIV.1 GROUPS A, B, C, D, E, F & G T6...T4
 XP CLASS I, DIV. 1 GROUPS A, B, C & D T4
 CLASS I, DIV. 2 GROUPS A, B, C & D T4
 CLASS II, III, DIV. 1 GROUPS E, F & G T4

Temperature class:
 T4 for -40°C ≤ ambient temperature ≤ +85°C
 T6 for -40°C ≤ ambient temperature ≤ +40°C

RF 8000 / CN 8000 unit

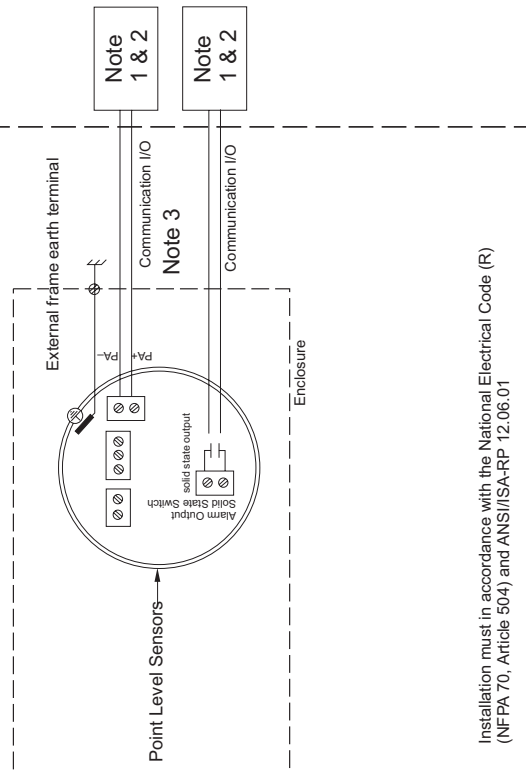

Installation must be in accordance with the National Electrical Code (R) (NFPA 70, Article 504) and ANSI/ISA-RP 12.06.01

Operation - Electronic module: Standard

Settings

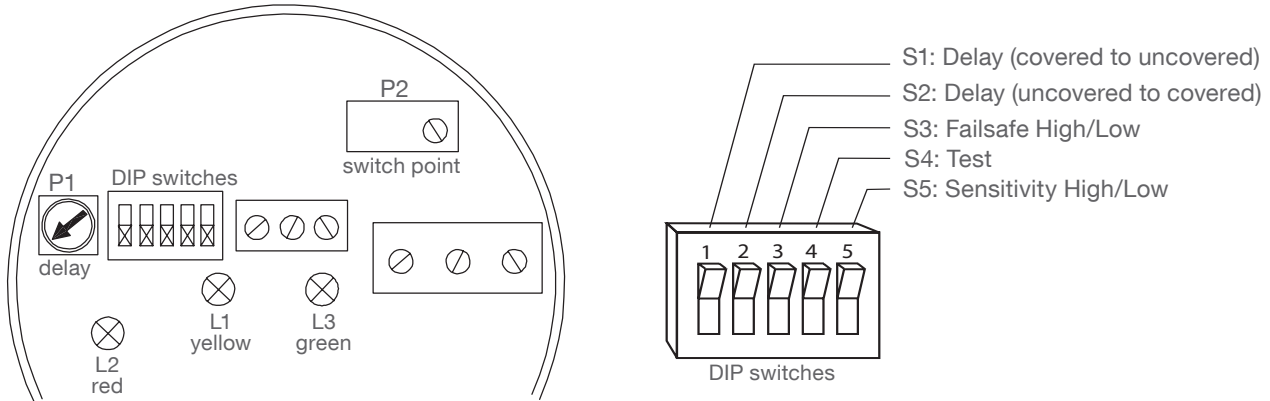

LEDs

- L1: Sensor status (yellow)
ON if sensor is detected as covered (capacitance on sensor is greater than setted switch point)
- L2: Signal output (red)
ON if Relay is activated / Solid state switch is closed.
- L3: Power supply (green)
ON if power is present

S1 / S2: Signal output delay

Use the delay function to slow the signal output response, and compensate for turbulence or false readings.

S1		<p>Signal output delay: Sensor covered to uncovered</p>	<p>P1 Delay time / seconds</p>
S2		<p>Signal output delay: Sensor uncovered to covered</p>	<p>P1 Delay time / seconds</p>

* Factory setting for units without overflow protection (WHG)

** Factory setting for units with overflow protection (WHG)

* Factory setting

S3: Failsafe High / Low

Failsafe Mode	S3		
Failsafe High **			
Failsafe Low *			



* Factory setting for units without overflow protection (WHG)

** Factory setting for units with overflow protection (WHG)

Operation - Electronic module: Standard



S4: Test

Allows to test the setted signal output delay time without the need to change the sensor from covered to uncovered or from uncovered to covered.

<p>S4</p> 	<p>Normal operation *</p>	
<p>S4</p> 	<p>Test mode</p>	<p>If sensor is uncovered: Setting S4 to Test mode simulates a covered probe. After the setted delay time "Sensor uncovered to covered" (see DIP switch S2) has passed, the signal output and LED2 (red) are switching.</p> <p>If sensor is covered: Setting S4 to Test mode simulates a uncovered probe. After the setted delay time "Sensor covered to uncovered" (see DIP switch S1) has passed, the signal output and LED2 (red) are switching.</p>

*Factory setting

S5: Sensitivity setting

<p>S5</p> 	<p>Low sensitivity</p>	<p>This setting is preferred for measuring conductive liquids, or viscous conductive solids that can build up on the sensor.</p>
<p>S5</p> 	<p>High sensitivity *</p>	<p>Use this setting for measuring dry solids or nonconductive liquids.</p>

* Factory setting

Units with overfill protection (WHG):

- DIP switches S1/ S2 and potentiometer P2 are fixed with removable glue. They can be changed if required.
- DIP switches S3/ S4/ S5 are fixed with non-removable glue. They can not be changed.



Operation - Electronic module: Standard

Switchpoint Adjustment

Select the switchpoint adjustment according to the application as follows:

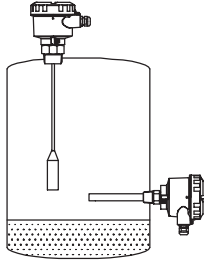

Application	Material	Adjustment conditions
General	<ul style="list-style-type: none"> • Dry solids • Low viscosity liquids 	Sensor uncovered
Demanding	<ul style="list-style-type: none"> • Hygroscopic / wet solids • High viscosity and high conductivity liquids 	Sensor immersed and then uncovered, retaining max. possible material buildup
Interface detection	<ul style="list-style-type: none"> • Ignoring liquid A / detecting liquid B • Ignoring foam / detecting liquid 	Immerse sensor in liquid A or foam

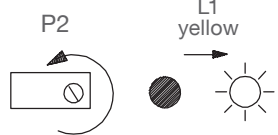
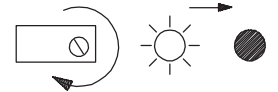
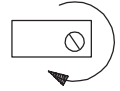
General applications

<p>1. Ensure material level is well below the probe</p>	<p>The unit will calibrate to an uncovered probe.</p> 								
<p>2. Set to high sensitivity</p>	<p>Set dip switch S5 to high sensitivity</p> 								
<p>3. Adjust switchpoint with poti P2</p>	<p>If LED L1 (yellow) is OFF, turn poti P2 counter clockwise until L1 is ON.</p>  <p>Turn P2 clockwise until L1 just stops glowing.</p>  <p>Turn P2 further clockwise:</p> <table border="1" data-bbox="502 1668 893 1859"> <thead> <tr> <th>Dielectric constant of material</th> <th>Number of turns</th> </tr> </thead> <tbody> <tr> <td>< 2</td> <td>1/8</td> </tr> <tr> <td>2 ... 4</td> <td>1/4</td> </tr> <tr> <td>> 4</td> <td>1/2</td> </tr> </tbody> </table> <p>Depending on the application and the required switchpoint the number of turns can be varied.</p> 	Dielectric constant of material	Number of turns	< 2	1/8	2 ... 4	1/4	> 4	1/2
Dielectric constant of material	Number of turns								
< 2	1/8								
2 ... 4	1/4								
> 4	1/2								
<p>Switchpoint adjustment is finished</p>									

Operation - Electronic module: Standard

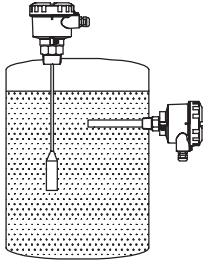
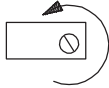
Demanding applications

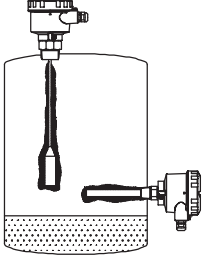
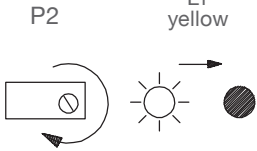
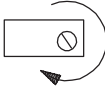
<p>1. Ensure material level is well above the probe.</p>	<p>In case of top mounting with rope extension the vessel should be filled up.</p>									
<p>2. Turn poti P2 to most sensitive position</p>	<p>Turn P2 fully counter clockwise</p>	<p>P2</p> 								
<p>3. Set sensitivity low or high</p>	<p>Set dip switch S5 to low sensitivity. L1 should glow.</p> <p>If L1 (yellow) does not glow, set S5 to high sensitivity. L1 should glow.</p> <p>Note: The appropriate position of S5 depends on the dielectric properties of the material.</p>	<p>S5 L1 yellow</p>  								
<p>4. Ensure material level is well below the probe</p>	<p>It is important that as much material buildup as possible is retaining on the sensor.</p>									
<p>5. Adjust switchpoint with poti P2</p>	<p>Turn P2 clockwise until L1 just stops glowing.</p> <p>Turn P2 further clockwise:</p> <table border="1" data-bbox="603 1742 986 1921"> <thead> <tr> <th>Dielectric constant of material</th> <th>Number of turns</th> </tr> </thead> <tbody> <tr> <td>< 2</td> <td>1/8</td> </tr> <tr> <td>2 ... 4</td> <td>1/4</td> </tr> <tr> <td>> 4</td> <td>1/2</td> </tr> </tbody> </table> <p>Depending on the application and the required switchpoint the number of turns can be varied.</p>	Dielectric constant of material	Number of turns	< 2	1/8	2 ... 4	1/4	> 4	1/2	<p>P2 L1 yellow</p>  
Dielectric constant of material	Number of turns									
< 2	1/8									
2 ... 4	1/4									
> 4	1/2									
<p>Switchpoint adjustment is finished</p>										

Operation - Electronic module: Standard

Interface detection

<p>1. Immerse probe in liquid A or in foam which should NOT be detected</p>	<p>Ensure that liquid A or foam (which should NOT be detected) is covering the probe.</p> <p>Liquid A or foam must have a lower dielectric constant than liquid B, which should be detected.</p>	<p>see note below for top mounted sensors *</p>								
<p>2. Turn poti P2 to most sensitive position</p>	<p>Turn P2 fully counter clockwise</p>	<p>P2</p>								
<p>3. Set sensitivity low or high</p>	<p>Set dip switch S5 to low sensitivity. L1 should glow.</p> <p>If L1 (yellow) does not glow, set S5 to high sensitivity. L1 should glow.</p> <p>Note: The appropriate position of S5 depends on the dielectric properties of the material.</p>	<p>S5 L1 yellow</p>								
<p>4. Adjust switchpoint with poti P2</p>	<p>Turn P2 clockwise until L1 just stops glowing.</p> <p>Turn P2 further clockwise:</p> <table border="1" data-bbox="507 1317 890 1496"> <thead> <tr> <th>Dielectric constant of material</th> <th>Number of turns</th> </tr> </thead> <tbody> <tr> <td>< 2</td> <td>1/8</td> </tr> <tr> <td>2 ... 4</td> <td>1/4</td> </tr> <tr> <td>> 4</td> <td>1/2</td> </tr> </tbody> </table> <p>Depending on the application and the required switchpoint the number of turns can be varied.</p> <p>Note: The sensitivity is now setted thus that liquid A or foam is NOT detected.</p>	Dielectric constant of material	Number of turns	< 2	1/8	2 ... 4	1/4	> 4	1/2	<p>P2 L1 yellow</p>
Dielectric constant of material	Number of turns									
< 2	1/8									
2 ... 4	1/4									
> 4	1/2									
<p>5. Immerse probe in liquid B which should be detected</p>	<p>Ensure that liquid B (which should be detected) is covering the probe.</p> <p>L1 should glow.</p>									
<p>Switchpoint adjustment is finished</p>										

* Interface detection with top mounted sensors is possible with detection of oil over water, since oil has a much lower dielectric constant compared to water. For other applications please contact manufacturer.

Operation - Electronic module: Standard

Troubleshooting

Symptom	Observation	Action
No Alarm Response	L3 (green) off.	Check power supply voltage.
Alarm doesn't switch when sensor is uncovered.	L1 (yellow) doesn't respond when sensor is uncovered.	Check sensitivity switch S5. Readjust trip point potentiometer P2.
	L1 (yellow) responds when sensor is uncovered.	Check that relay changes state when S3 is toggled ON and OFF.
Alarm doesn't switch on when sensor is covered.	L1 (yellow) doesn't respond when sensor is covered.	Check sensitivity switch S5. Readjust trip point potentiometer P2.
	L1 (yellow) responds when sensor is covered.	Check that relay changes state when S3 is toggled ON and OFF.
	L1 (yellow) flashes when material level approaches the alarm setpoint.	

Operation - Electronic module: Digital

See separate "Operating Manual (Digital Electronic)"

Notes for use in Hazardous Locations

Use of this Manual

For use and assembly, refer to the instructions in this Manual. It does contain all instruction as required by ATEX Directive 2014_34_EU, Annex II, 1/0/6 and Ordinance INMETRO n° 179/2010

General notes

Refer to appropriate certificate for application in specific hazardous environment.

The equipment has not been assessed as a safety related device (as referred to by Directive 2014_34_EU Annex II, clause 1.5).

The certificate numbers have an 'X' suffix, which indicates that specific condition of use apply. Those installing or inspecting this equipment must have access to the certificates.

! Qualification of personnel / Servicing / Repair

Installation and inspection of this equipment shall be carried out by suitably trained personnel in accordance with the applicable code of practice (ABNT NBR IEC/EN 60079-14 and ABNT/NBR IEC/EN 60079-17 in Europe).

Repair of this equipment shall be carried out by suitably trained personnel in accordance with the applicable code of practice (e.g. ABNT NBR IEC/EN 60079-19 within Europe).

Repair of flameproof path is not intended.

Components to be incorporated into or used as replacements in the equipment shall be fitted by suitably trained personnel in accordance with the manufacturer's documentation.

In potentially explosive atmospheres open the enclosure only when RF 8000 is not energized.
 Turn off power before servicing any device (the transmitter is in operation when the power supply is switched on).
 In case of removing the unit from vessel, take care of process pressure and material passing the opening.

ATEX: Certificates / List of Standards

Certificate numbers: DEKRA 18ATEX0045 X and DEKRA 18ATEX0046 X

See www.uwt.de for the latest certificates

See EU - Declaration of conformity for the list of standards valid for ATEX certificates

ATEX: Year of manufacturing

Marking on the name plate is done according to IEC 60062 as follows:

Year of manufacturing	2018	2019	2020	2021	2022	2023	2024	2025	2026	2027	2028	2029
Marking code	K	L	M	N	P	R	S	T	U	V	W	X

Notes for use in Hazardous Locations

ATEX: Ex-Marking

- Devices with ATEX approval are marked on the name plate as follows.
- If both Flameproof and Dust ignition proof are present on the same nameplate, a tick box is present where the end user needs to select (mark) the protection method used at the time of installation.

Dust Ignition Proof with intrinsically safe output to probe (Typecode Pos.2 W)

Electronic module: Standard and Digital

RF 8100: II 1/2 D Ex ia/tb [ia Da] IIIC TX Da/Db

RF 8200 High temp version: II 1/2 D Ex ia/tb [ia Da] IIIC TX Da/Db

Flameproof / Dust Ignition Proof with intrinsically safe output to probe (Typecode Pos.2 T)

Electronic module: Standard and Digital

RF 8100: II 1/2 G Ex ia/db [ia Ga] IIC TX Ga/Gb

II 1/2 D Ex ia/tb [ia Da] IIIC TX Da/Db

RF 8200 High temp version: II 1/2 G Ex ia/db [ia Ga] IIC TX Ga/Gb

II 1/2 D Ex ia/tb [ia Da] IIIC TX Da/Db

Intrinsically Safe (Typecode Pos.2 Y)

Electronic module: Digital

RF 8100: II 1 G Ex ia IIC TX Ga

II 1/2 D Ex ia IIIC TX Da/Db

RF 8200 High temp version: II 1 G Ex ia IIC TX Ga

II 1/2 D Ex ia IIIC TX Da/Db

! Permitted zones for installation

Devices can be installed as follows:

	Dust applications		Gas applications	
	marking Da/Db	marking Ga/Gb	marking Ga	marking Ga
EPL	Db	Gb	Ga	Ga
Category	2D	2G	1G	1G
Zone	21	1	0	0

	Dust applications	Gas applications	Gas applications
	marking Da/Db	marking Ga/Gb	marking Ga
EPL	Da	Ga	Ga
Category	1D	1G	1G
Zone	20	0	0

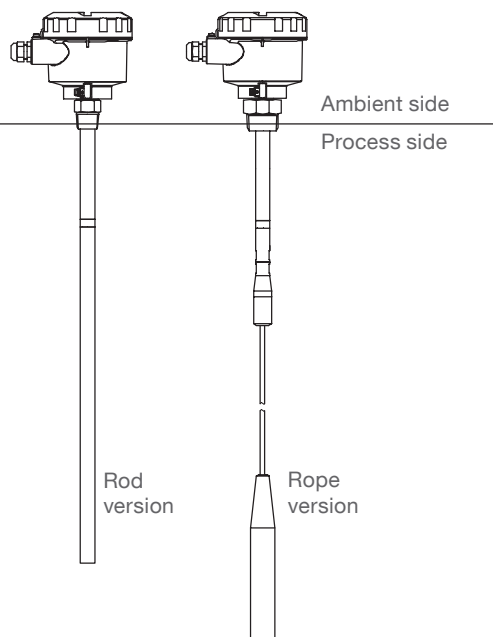

Notes for use in Hazardous Locations

! Specific condition of use

Electrostatic charge The user shall ensure that the equipment is not installed in a location where it may be subjected to external conditions which might cause a build-up of electrostatic charge on non-conducting surfaces.

Impact / Friction Because the enclosure and optionally the process connection of the equipment is made of aluminium alloy, the apparatus must be installed so, that even in the event of rare incidents, an ignition source due to impact or friction between enclosure and iron / steel is excluded, when used in potentially explosive atmosphere requiring apparatus of equipment 1G.

Flameproof joints The flameproof joints are not intended to be repaired.

Ambient and process temperature range The relation between the ambient and process temperature ranges and the surface temperature or temperature class is shown in the thermal data tables page 35.

Max. permitted temperature close to the enclosure If the process temperature exceeds the max. permissible ambient temperature, the max. resulting temperature at the connection of the sensor head (see dotted line) shall not exceed the related max. permissible ambient temperature (see page 35), taking the worst case conditions into account. This shall be verified by measurement when installed.

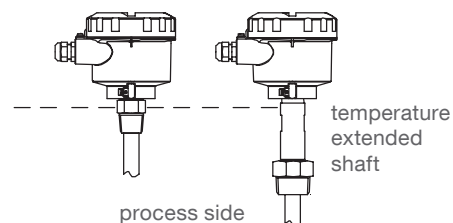

! Warnings for installation

Intrinsically safe supply For intrinsically safe models, power must be supplied from an Intrinsically Safe power source, otherwise protection is no longer guaranteed.

Process pressure Devices with Ex Approval are approved for atmospheric pressure. A detailed explanation is given below for ATEX and applies analogously for other Ex approvals: The scope of the ATEX directive is generally limited to atmospheric pressure, see ATEX directive 2014_34_EU Chapter 1 Art.2 (4). Atmospheric pressure is defined as absolute pressure 0.8bar to 1.1bar, see ATEX guideline §50 and IEC 60079-0 chapter 1 Scope. The technical background is that an explosive atmosphere which is compressed (overpressure) or released (underpressure) can exhibit different explosion behaviour than under atmospheric conditions. The standards for the types of protection against explosion (IEC 60079 series), on which a type approval according to the ATEX directive is based, are designed for atmospheric conditions and do not automatically cover deviating pressure conditions. Thus, an ATEX type approval issued in accordance with this directive only covers atmospheric pressure. This applies to all manufacturers. A deviating operating pressure can be assessed and approved by an expert for the respective application. Regardless of this, the design of the level indicators is suitable for a vessel overpressure / underpressure in accordance with the specified technical data.

Notes for use in Hazardous Locations

! Warnings for installation

Process and ambient temperature Please check the ambient and process temperatures page 35 for the specific configuration you are about to use or install.

Chemical resistance against the medium If the equipment is likely to come into contact with aggressive substances, then it is the responsibility of the user to take suitable precautions that prevent it from being adversely affected, thus ensuring that the type of protection is not compromised. Aggressive substances: e.g. acidic liquids or gases that may attack metals, or solvents that may affect polymeric materials. Suitable precautions: e.g. establishing from the material's data sheet that it is resistant to specific chemicals.

Cable entry devices / blanking elements general

Dust Ignition Proof:
 For use in potentially explosive dust atmospheres:
 The cable entry devices and the blanking elements of unused apertures shall be of a certified type, suitable for the conditions of use and correctly installed.
 The minimum ingress protection requirement of IP6X according to EN 60529 must be satisfied.

Flameproof:
 For use in potentially explosive gas atmospheres:
 The cable entry devices and the blanking elements of unused apertures shall be of a certified flameproof type, suitable for the conditions of use and correctly installed.

Intrinsically Safe:
 The cable entry devices and the blanking elements of unused apertures shall be of a certified type, suitable for the conditions of use and correctly installed.
 The minimum ingress protection requirement of IP64 according to EN 60529 must be satisfied.

Versions with cable gland mounted by default:
 The used cable gland is only suitable for fixed installations.
 The installer is responsible for providing appropriate strain-relief to prevent pulling or twisting.

Versions with blanking element mounted by default:
 Blanking elements are not to be used with any form of adaptors or reducers.

Versions with cable gland / blanking element mounted by default

Below-mentioned cable diameters and tightening torques of the nut resp. blanking element shall be observed for the installation.

Cable gland M20x1.5 (Dust Ignition Proof, Intrinsically Safe)
 Cable diameter: 6 mm to 12 mm
 Tightening torque: Depending on the used cable and therefore to be determined by the user

Cable gland M20x1.5 (Flameproof)
 Cable diameter: Bedding 3.1 mm to 8.6 mm / Overall 6.1 mm to 13.1 mm
 Tightening torque: Number of turns depending on the overall cable diameter of the used cable
 (e. g. 1 turn / cable diameter 12.5 mm to 5.5 turns / cable diameter 6.5 mm)

Blanking element M20x1.5 (all versions)
 Tightening torque: 32.5 Nm

Notes for use in Hazardous Locations

- ! Ambient and Process temperature range,
- max. Surface Temperature and Temperature Class

ATEX/ INMETRO/ TR-CU:

Flameproof and Dust Ignition Proof with intrinsically safe output to probe
 Electronic module: Standard and Digital

Ambient temperature range	Process temperature range	Max. Surface temperature (EPL Da)	Max. Surface temperature (EPL Db)	Temperature class (EPL Ga or Gb)
-40 to +70°C (-40 to +158°F)	-40 to +75°C (-40 to +167°F) (1)	T ₂₀₀ 80°C	T80°C	T6
-40 to +80°C (-40 to +176°F)	-40 to +90°C (-40 to +194°F) (1) (2)	T ₂₀₀ 95°C	T90°C	T5
-40 to +80°C (-40 to +176°F)	-40 to +125°C (-40 to +257°F) (1) (2)	T ₂₀₀ 130°C	T90°C	T4
-40 to +80°C (-40 to +176°F)	-40 to +190°C (-40 to +374°F) (1) (2)	T ₂₀₀ 195°C	T90°C	T3
-40 to +80°C (-40 to +176°F)	-40 to +285°C (-40 to +545°F) (3)	T ₂₀₀ 290°C	T90°C	T2
-40 to +80°C (-40 to +176°F)	-40 to +400°C (-40 to +752°F) (3)	T ₂₀₀ 405°C	T90°C	T1

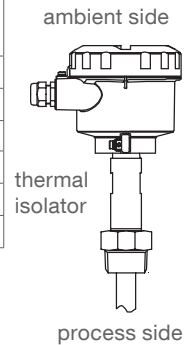

Intrinsically safe

Electronic module: Digital

Ambient temperature range	Process temperature range	Max. Surface temperature (EPL Da)	Max. Surface temperature (EPL Db)	Temperature class (EPL Ga)
-40 to +60°C (-40 to +140°F)	-40 to +75°C (-40 to +167°F) (1)	T ₂₀₀ 80°C	T70°C	T6
-40 to +60°C (-40 to +140°F)	-40 to +90°C (-40 to +194°F) (1) (2)	T ₂₀₀ 95°C	T70°C	T5
-40 to +60°C (-40 to +140°F)	-40 to +125°C (-40 to +257°F) (1) (2)	T ₂₀₀ 130°C	T70°C	T4
-40 to +60°C (-40 to +140°F)	-40 to +190°C (-40 to +374°F) (1) (2)	T ₂₀₀ 195°C	T70°C	T3
-40 to +60°C (-40 to +140°F)	-40 to +290°C (-40 to +554°F) (3)	T ₂₀₀ 295°C	T70°C	T2
-40 to +60°C (-40 to +140°F)	-40 to +400°C (-40 to +752°F) (3)	T ₂₀₀ 405°C	T70°C	T1

(1) With option FFKM O-ring seal: Lower process temperature limited to -20 °C (-4°F)

(2) For process temperature > 85 °C: Only applicable for versions with thermal isolator or for High temperature version

(3) Only applicable for High temperature version

FM/ CSA:

Explosion proof / Dust ignition proof

Ambient temperature range	Temperature class
-40 to +85°C (-40 to +185°F)	T4

Intrinsically safe

Installation shall be done according to "FM/CSA Approval - Connection drawing" on page 23

Ambient temperature range	Temperature class
-40 to +40°C (-40 to +40°F)	T6
-40 to +85°C (-40 to +185°F)	T4

Process temperature is not considered for definition of Temperature class.

Probe modifications

Shortening the rope (rope version)

CAUTION:

When shortening a PFA rope, be sure to take extra care not to damage the PFA coating.

Methods

An angle grinder (preferably with a disc suitable for stainless steel) or
 Wire cutters (suitable for piano rope Ø 6 to 9 mm).

Procedure

1. Loosen the three set screws and pull weight from the rope.
2. Grind/cut the rope to the required length, and then remove rough edges from the rope.
3. Ensure that rope strands are properly seated in the lay of the rope (i.e. no wire strands sticking outside the normal rope profile). Make sure ALL strands are properly seated before continuing the assembly.
4. Push the weight onto the rope while simultaneously rotating it counter-clockwise around the rope. Make sure that no rope strands are pushed out of their position in the rope and that the rope is fully inserted.
5. Re-fasten the weight by tightening the three set screws.

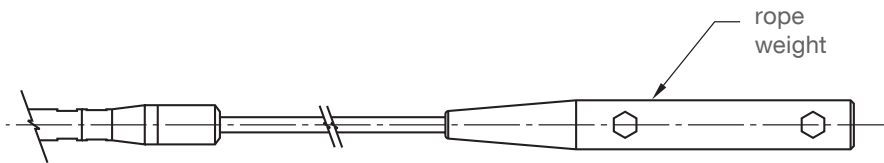

Shortening the rod (rod version)

Cut the rod with an angle grinder (preferably with a disc suitable for stainless steel)

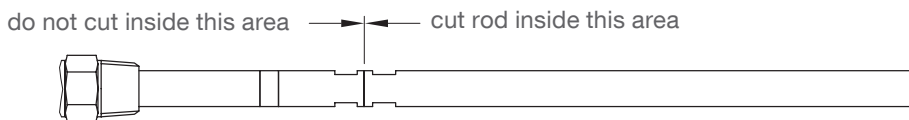

Change rod to rope or rope to rod

Unscrew the probe at the dotted line and replace by a different probe.

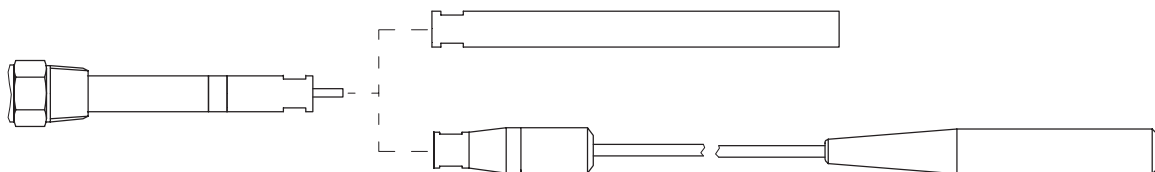

Disposal

The product consists of materials which can be recycled, details of the used materials see chapter "Technical data - mechanical data". Recycling must be done by a specialised recycling company.