

FAIRCHILD MODEL 81 PNEUMATIC MULTI-STAGE REGULATOR

Installation, Operation and Maintenance Instructions

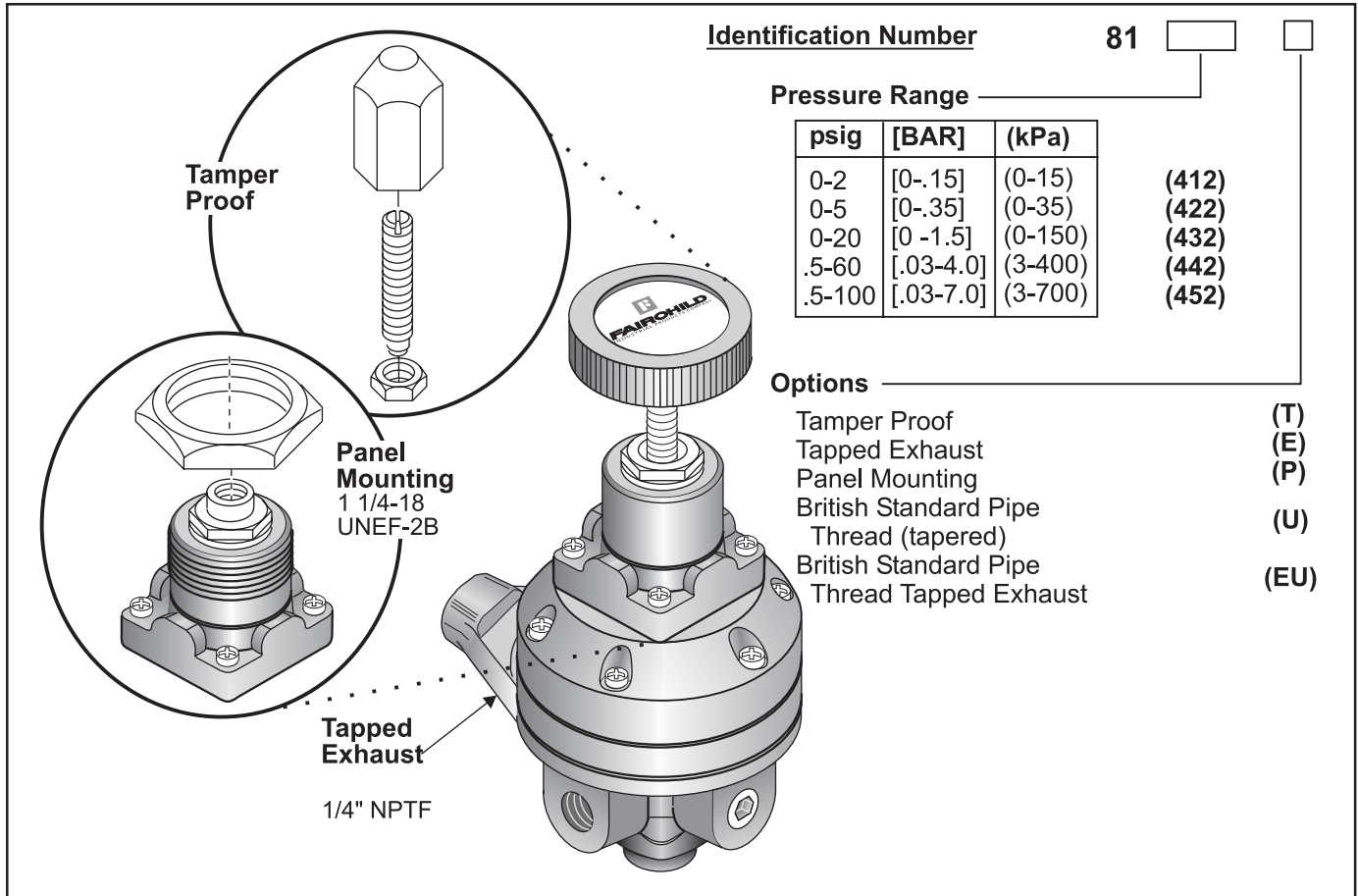

Figure 1. Model 81 Multi-Stage Pressure Regulator Identification Number System.

GENERAL INFORMATION

The Model 81 is a precision two-stage regulator. The regulator combines a pilot control system with a basic force balance system to provide accurate output pressure regulation.

ADJUSTMENTS

The Model 81 Regulator does not require field adjustments.

SPECIFICATIONS

Functional Specifications			
Supply Pressure	psig	[BAR]	(kPa)
Maximum	150	[10]	(1000)
Minimum	20	[1.5]	(150)
Output Pressure Maximum	100	[7]	(700)

Specifications (continued)

Flow Capacity (Nominal)	50 SCFM (85m ³ /HR) @ 100 psig [7 BAR] (700 kPa) Supply & 20 psig [1.5 BAR] (150 kPa) Set.
Exhaust Capacity	5.5 SCFM (9.4m ³ /HR) @ Downstream Pressure 5 psig [3.5 BAR] (35 kPa) above 20 psig [1.5 BAR] (150 kPa) Set Pressure.
Ambient Temperature Limits	-40 F to +200 F (-40 C to +93.3 C)
Air Consumption	Less than .1 SCFM (.17m ³ /HR)
Performance Specifications	
Sensitivity	Less than 0.1" (.254 cm) Water Column
Supply Pressure Effect	Less than .2 psig [.015 BAR] (1.5 kPa) for 100 psig [7 BAR] (700 kPa) Change
Materials of Construction	Body and Housing Aluminum Trim Stainless Steel, Brass, Aluminum, Plated Steel Diaphragms Buna N on Dacron Orifice Sapphire

INSTALLATION

Clean all pipelines to remove dirt and scale before installation. **If you use a pipe compound when installing pipe or tube fittings into the regulator, use a teflon dope as a sealant.**

Apply a minimum amount of pipe compound to the male threads of the fitting only. Start with the third thread back and work away from the end of the fitting to avoid the possibility of contaminating the regulator. Install the regulator in the air line.

The regulator can be mounted in any position without affecting its operation. It can be wall mounted by using Mounting Bracket 11989 shown in Figure 3.

The inlet and outlet connections are labeled on the underside of the regulator with the arrows pointing in the direction of the flow. Tighten connections securely. Avoid undersized fittings that will limit the flow through the regulator and cause a pressure drop downstream. For more information, see Figure 2. "Outline Dimensions".

NOTE: Oil free air must be applied to the regulator. Use a filter to remove dirt and entrained liquid in the air line ahead of the regulator. If an air line lubricator is used, it MUST be located downstream of the regulator, to avoid interference with regulator performance.

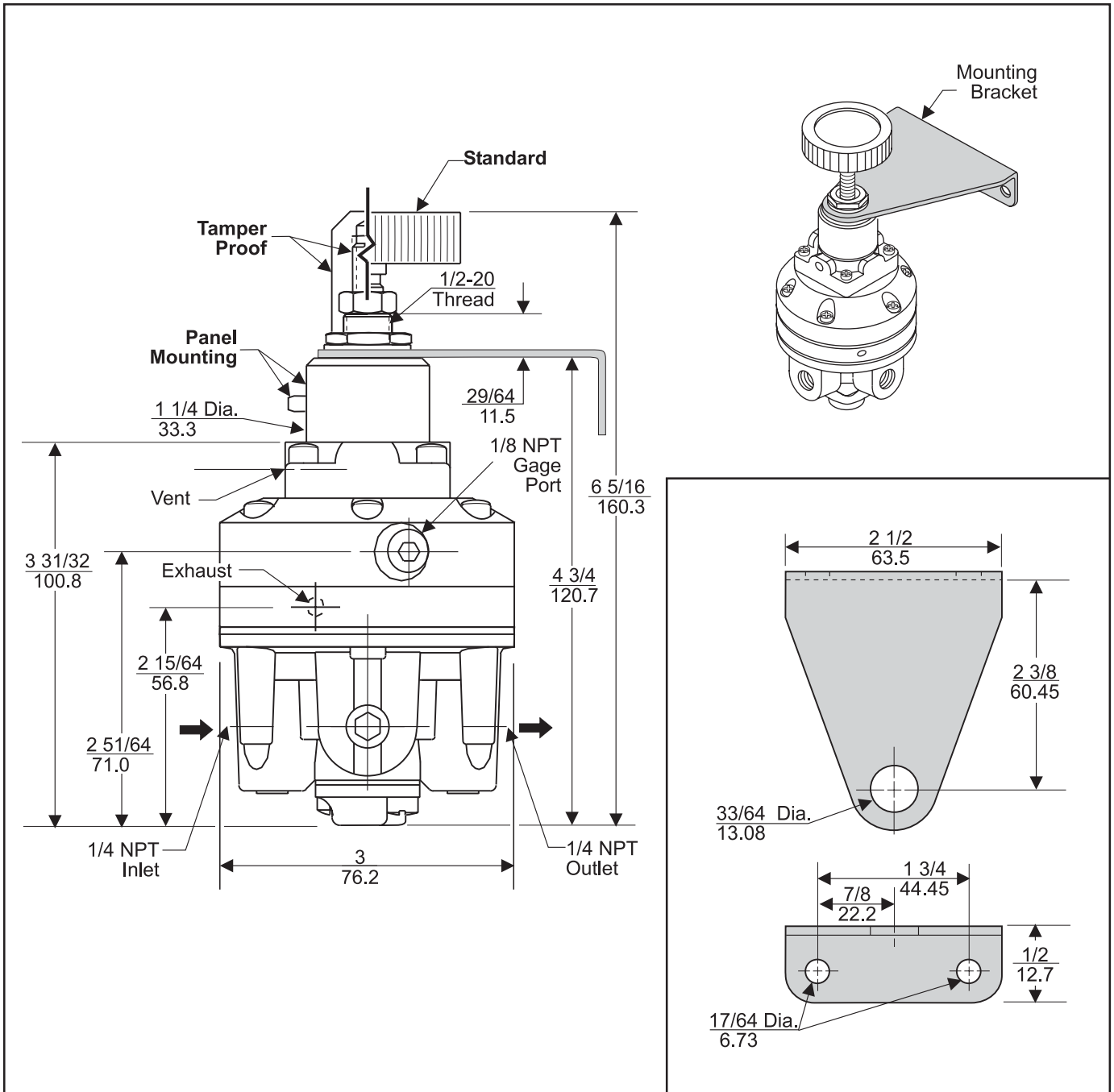
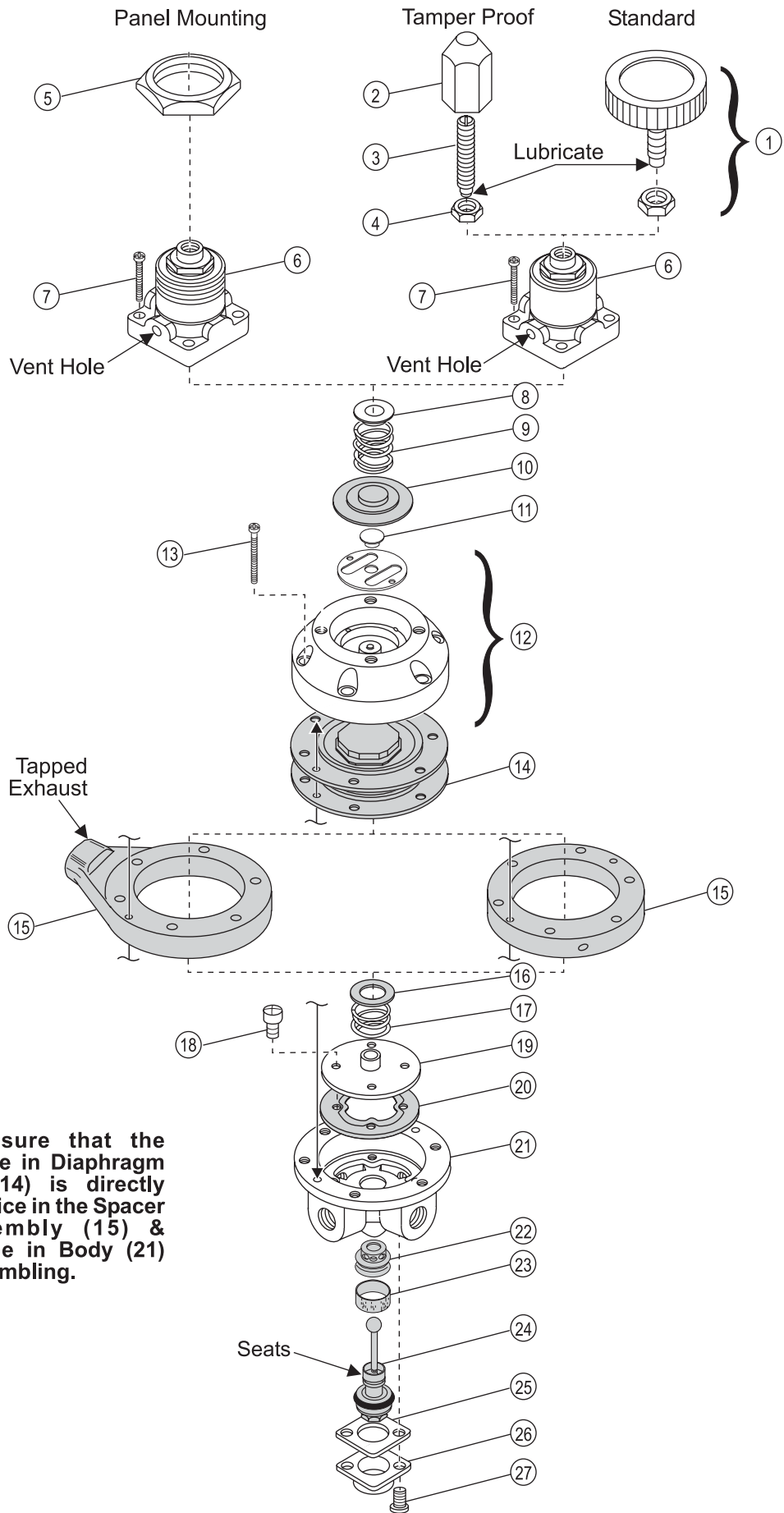

Figure 2. Outline Dimensions

Figure 3. Mounting Bracket 11989



NOTE: Insure that the passage hole in Diaphragm Assembly (14) is directly over the Orifice in the Spacer Ring Assembly (15) & passage hole in Body (21) when reassembling.

Figure 4. Exploded Drawing

MAINTENANCE

To clean the Model 81, use the following procedure:

1. During disassembly, shut off the valve that is supplying air to the regulator. This is to prevent air from escaping. **It is not necessary to remove the regulator from the air line.**
2. Remove the two Screws (27) from bottom of the unit.
3. Pull out the Inner Valve Assembly (24). Wash the Seats on the Inner Valve Assembly carefully.
4. Wipe off any particles that may be attached to rubber Seat Ring (22) in Body.
5. Replace the assembly carefully.
6. Keep the vent hole in the Bonnet clear for proper regulator operation. Lubricate the adjusting screw with Molycote "G". For more information, see Figure 4. "Exploded Drawing" on page 3.

NOTE: Avoid such solvents as acetone, carbon tetrachloride, and trichlorethylene.

TROUBLE-SHOOTING

Table 1. Trouble-Shooting	
Problem	Solution
Leakage	Check Body Screw tightness. Check Diaphragm.
High Bleed	Check Relief Pintle and Relief Seat for damage or contamination.
Difficult to adjust	Check Adjusting Screw and Ball lubrication.

MODEL 81 COMPONENTS

Table 2. Model 81 Components		
Item	Qty.	Description
1	1	Knob Assembly
2	1	Cap Nut
3	1	Slotted Set Screw
4	1	Jam Nut
5	1	Jam Nut
6	1	Bonnet Assembly
7	4	Screw
8	1	Spring Seat
9	1	Range Spring
10 ¹	1	Diaphragm Assembly
11	1	Anvil
12	1	Pilot Body Assembly
13	6	Screw
14 ²	1	Control Diaphragm Assembly (20, 60, and 100 psig)
14 ³	1	Control Diaphragm Assembly (2 & 5 psig)
15 ¹	1	Spacer Ring Assembly
16 ¹	1	Washer
17	1	Spring
18	4	Screw
19	1	Seal Plate Assembly
20 ¹	1	Seal Plate Gasket
21	1	Body
22 ¹	1	Seat Ring Assembly
23 ¹	1	Screen
24 ¹	1	Inner Valve Assembly
25	1	Retainer Plate
26	1	Retainer Cap
27	2	Screw

¹ 12922-1 & 12922-2 Service Kit Components.
² 12922-1 Service Kit Components.
 0-20, .5-60, .5-100 psig
 [0-1.5, .03-4.0, .03-7.0 BAR]
 (0-150, 3-400, 3-700 kPa)
³ 12922-2 Service Kit Components.
 0-2, 0-5 psig
 [0-.15, 0-.35 BAR]
 (0-15, 0-35 kPa)

LEGAL NOTICE:

The information set forth in the foregoing Installation, Operation and Maintenance Instructions shall not be modified or amended in any respect without prior written consent of Fairchild Industrial Products Company. In addition, the information set forth herein shall be furnished with each product sold incorporating Fairchild's unit as a component thereof.